

STEREO RECEIVER RX-797

SERVICE MANUAL

IMPORTANT NOTICE

This manual has been provided for the use of authorized YAMAHA Retailers and their service personnel. It has been assumed that basic service procedures inherent to the industry, and more specifically YAMAHA Products, are already known and understood by the users, and have therefore not been restated.

WARNING: Failure to follow appropriate service and safety procedures when servicing this product may result in personal injury, destruction of expensive components, and failure of the product to perform as specified. For these reasons, we advise all YAMAHA product owners that any service required should be performed by an authorized YAMAHA Retailer or the appointed service representative.

IMPORTANT: The presentation or sale of this manual to any individual or firm does not constitute authorization, certification or recognition of any applicable technical capabilities, or establish a principle-agent relationship of any form.

The data provided is believed to be accurate and applicable to the unit(s) indicated on the cover. The research, engineering, and service departments of YAMAHA are continually striving to improve YAMAHA products. Modifications are, therefore, inevitable and specifications are subject to change without notice or obligation to retrofit. Should any discrepancy appear to exist, please contact the distributor's Service Division.

WARNING: Static discharges can destroy expensive components. Discharge any static electricity your body may have accumulated by grounding yourself to the ground buss in the unit (heavy gauge black wires connect to this buss).

IMPORTANT: Turn the unit OFF during disassembly and part replacement. Recheck all work before you apply power to the unit.

■ CONTENTS

TO SERVICE PERSONNEL	2	IC DATA	17-18
IMPEDANCE SELECTOR	3	DISPLAY DATA	19
FRONT PANELS	3	PRINTED CIRCUIT BOARD	20-28
REAR PANELS	4-5	PIN CONNECTION DIAGRAM	29
REMOTE CONTROL PANELS	5	BLOCK DIAGRAM	30
SPECIFICATIONS	6-7	SCHEMATIC DIAGRAM	31-34
INTERNAL VIEW	7	PARTS LIST	35-43
DISASSEMBLY PROCEDURES	8	REMOTE CONTROL RAX100/RAX101	44
SELF DIAGNOSIS FUNCTION	9-15	REMOTE CONTROL RAX17	45
AMP ADJUSTMENT	16	REMOTE CONTROL RAX18	46



このサービスマニュアルは、エコマーク認定の再生紙を使用しています。
This Service Manual uses recycled paper.

100979

© 2005 YAMAHA CORPORATION. All rights reserved.
This manual is copyrighted by YAMAHA and may not be copied or redistributed either in print or electronically without permission.



YAMAHA

YAMAHA CORPORATION
P.O.Box 1, Hamamatsu, Japan

Printed in Japan '05.10

RX-797

■ TO SERVICE PERSONNEL

- Critical Components Information**
Components having special characteristics are marked  and must be replaced with parts having specifications equal to those originally installed.
- Leakage Current Measurement (For 120V Models Only)**
When service has been completed, it is imperative to verify that all exposed conductive surfaces are properly insulated from supply circuits.
 - Meter impedance should be equivalent to 1500 ohms shunted by 0.15µF.

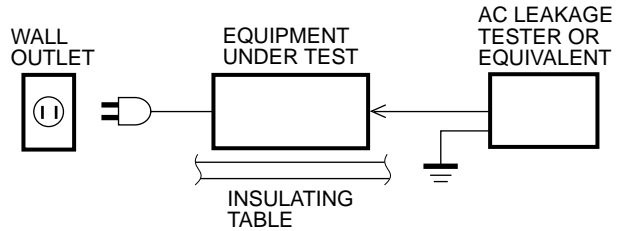

- Leakage current must not exceed 0.5mA.
- Be sure to test for leakage with the AC plug in both polarities.



“CAUTION”

“F251, F252 : FOR CONTINUED PROTECTION AGAINST RISK OF FIRE, REPLACE ONLY WITH SAME TYPE 8A, 125V FUSE.”

CAUTION

F251, F252 : REPLACE WITH SAME TYPE 8A, 125V FUSE.

ATTENTION

F251, F252 : UTILISER UN FUSIBLE DE RECHANGE DE MEME TYPE DE 8A, 125V.

WARNING: CHEMICAL CONTENT NOTICE!

The solder used in the production of this product contains LEAD. In addition, other electrical/electronic and/or plastic (where applicable) components may also contain traces of chemicals found by the California Health and Welfare Agency (and possibly other entities) to cause cancer and/or birth defects or other reproductive harm.

DO NOT PLACE SOLDER, ELECTRICAL/ELECTRONIC OR PLASTIC COMPONENTS IN YOUR MOUTH FOR ANY REASON WHATSOEVER!

Avoid prolonged, unprotected contact between solder and your skin! When soldering, do not inhale solder fumes or expose eyes to solder/flux vapor!

If you come in contact with solder or components located inside the enclosure of this product, wash your hands before handling food.

About Lead Free Solder

The P.C.B.s installed in this unit are soldered using the following solder.

	SIDE A	SIDE B
FUNCTION P.C.B.	-	Lead Free Solder
OPERATION P.C.B.	-	Lead Free Solder
MAIN P.C.B.	-	Lead Free Solder
XM P.C.B.	Lead Free Solder	Lead Free Solder

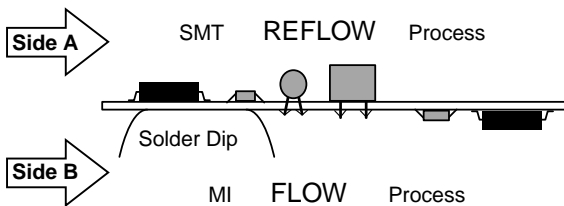

Among some types of lead free solder currently available, it is recommended to use one of the following types for the repair work.

- Sn + Ag + Cu (tin + silver + copper)
- Sn + Cu (tin + copper)
- Sn + Zn + Bi (tin + zinc + bismuth)

Caution:

- As the melting point temperature of the lead free solder is about 30°C to 40°C (50°F to 70°F) higher than that of the lead solder, be sure to use a soldering iron suitable to each solder.
- If lead solder must be used, be sure to remove lead free solder from each terminal section of the parts to be replaced and from the area around it completely before soldering, or make sure that the lead free solder and lead solder melt together fully.

■ IMPEDANCE SELECTOR

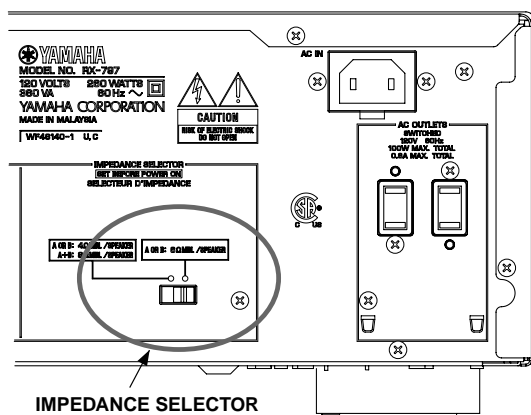

WARNING:

Do not change the setting of the IMPEDANCE SELECTOR switch when the unit power is switched on, as doing so may damage the unit.

■ FRONT PANELS

▼ U, C models

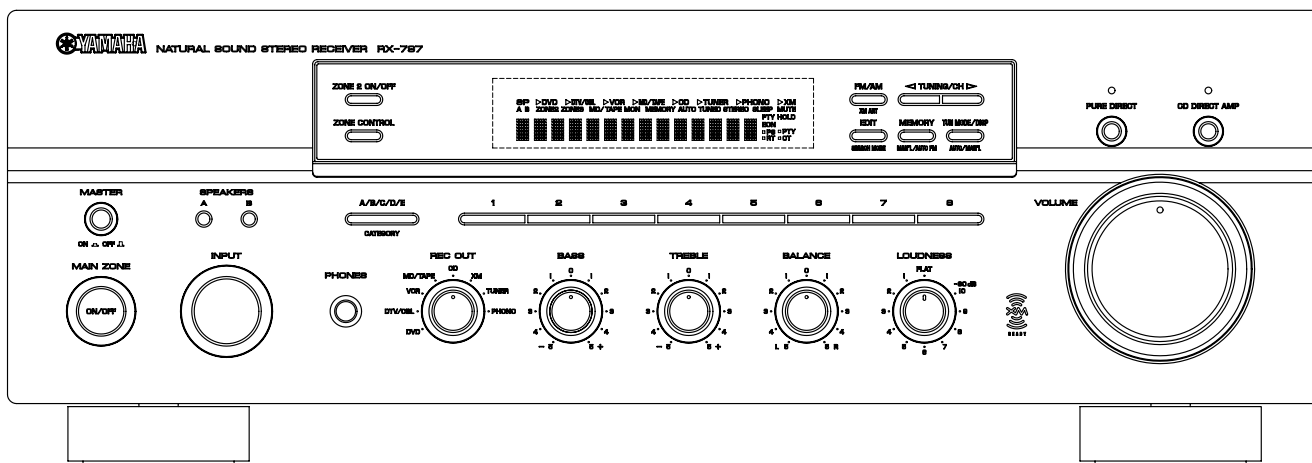

▼ R, A, G, E, L models

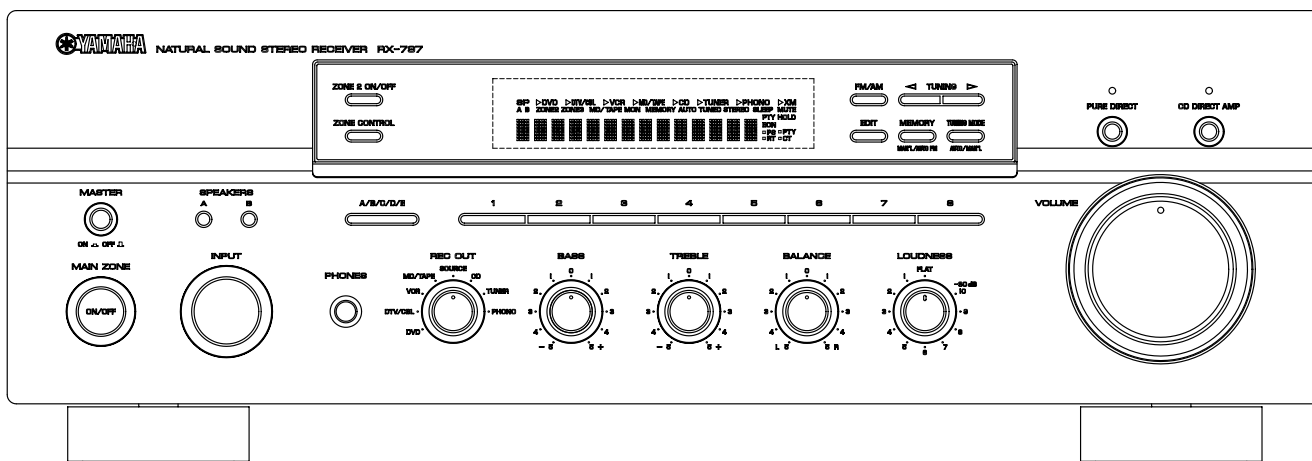

RX-797

REAR PANELS

U, C models

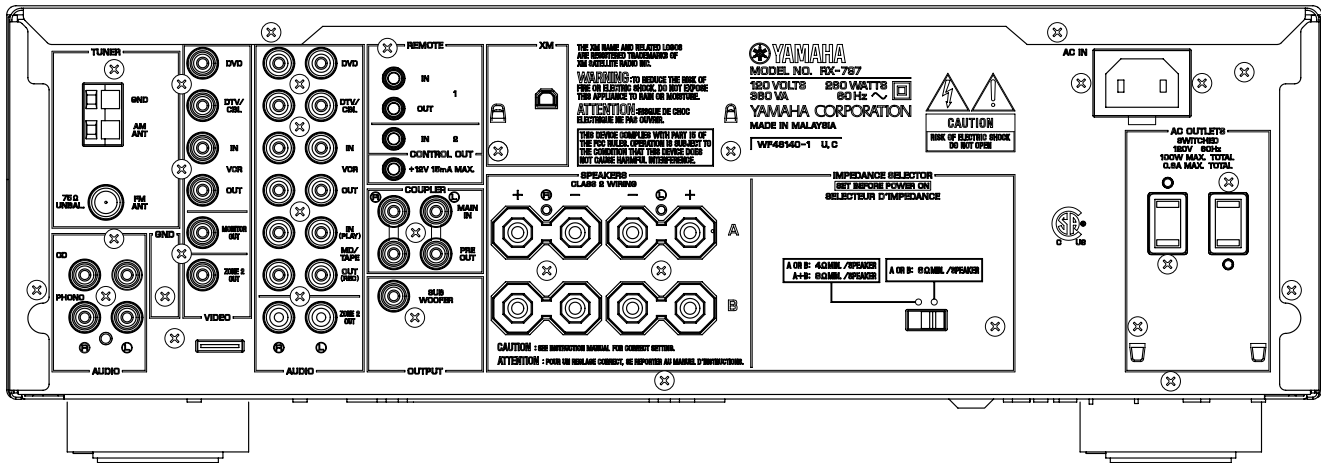

R model

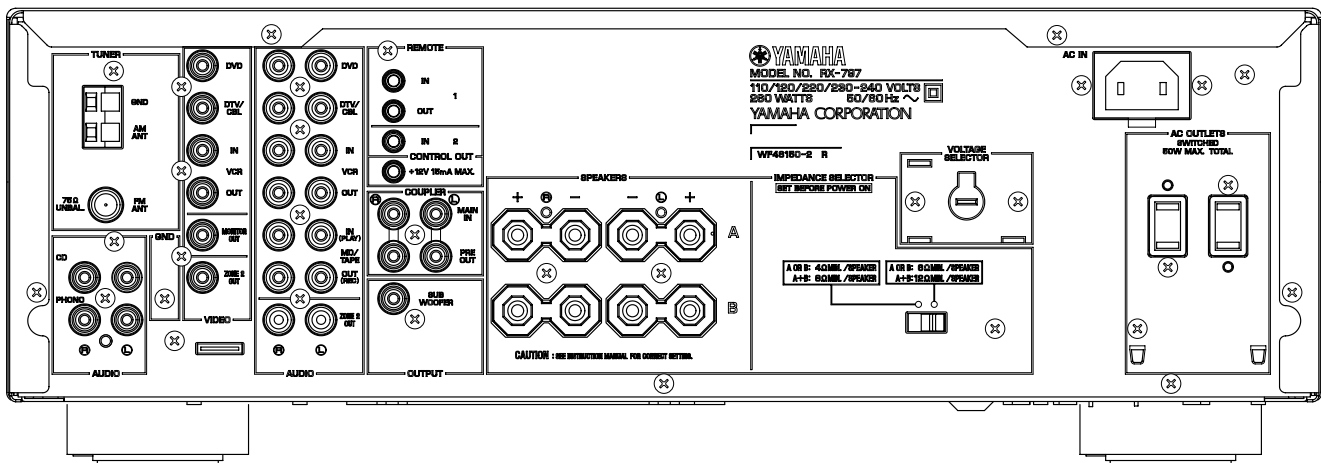

A model

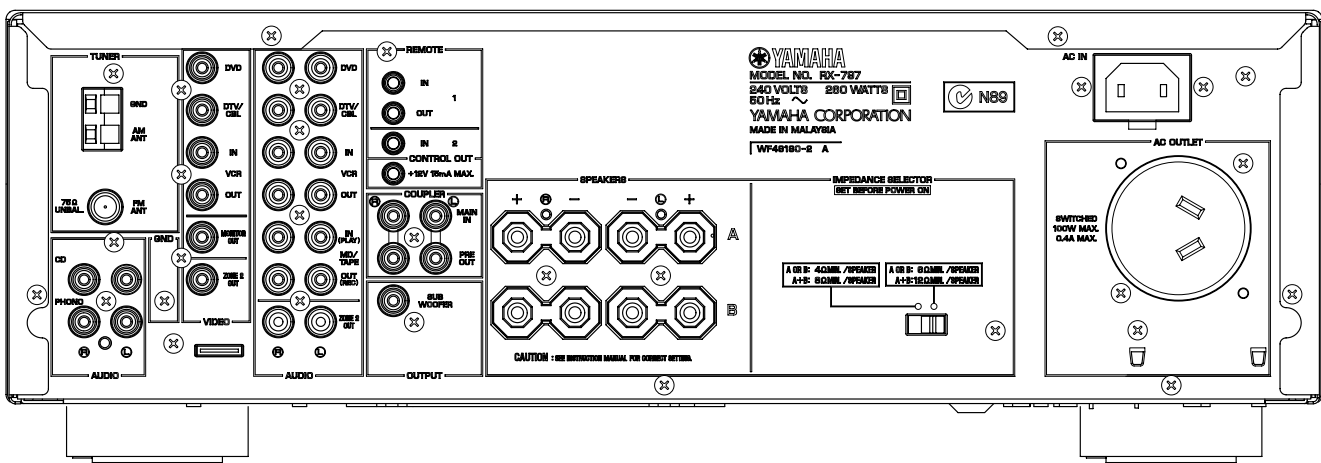

RX-797

▼ G, E models

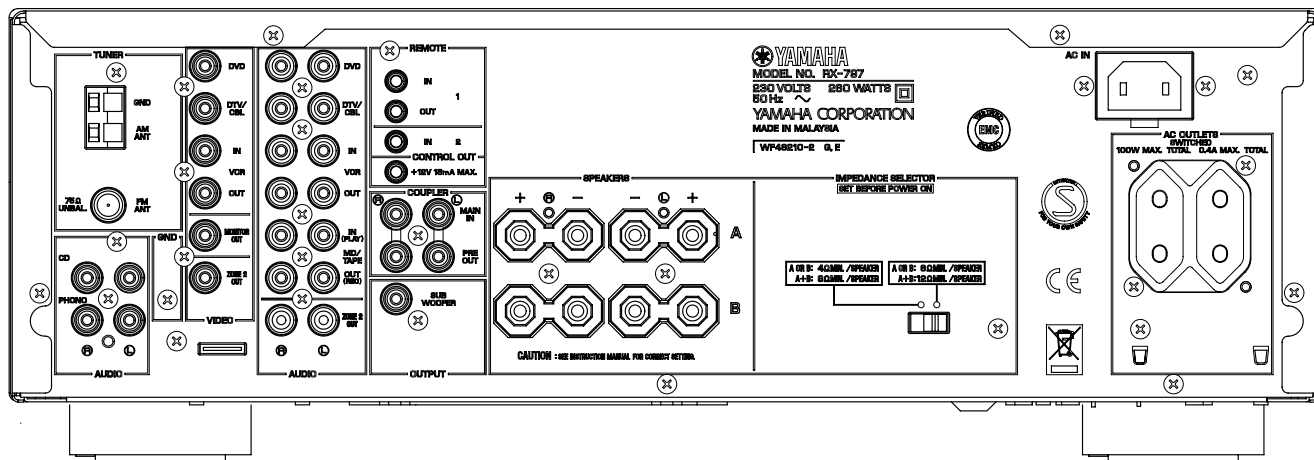

▼ L model

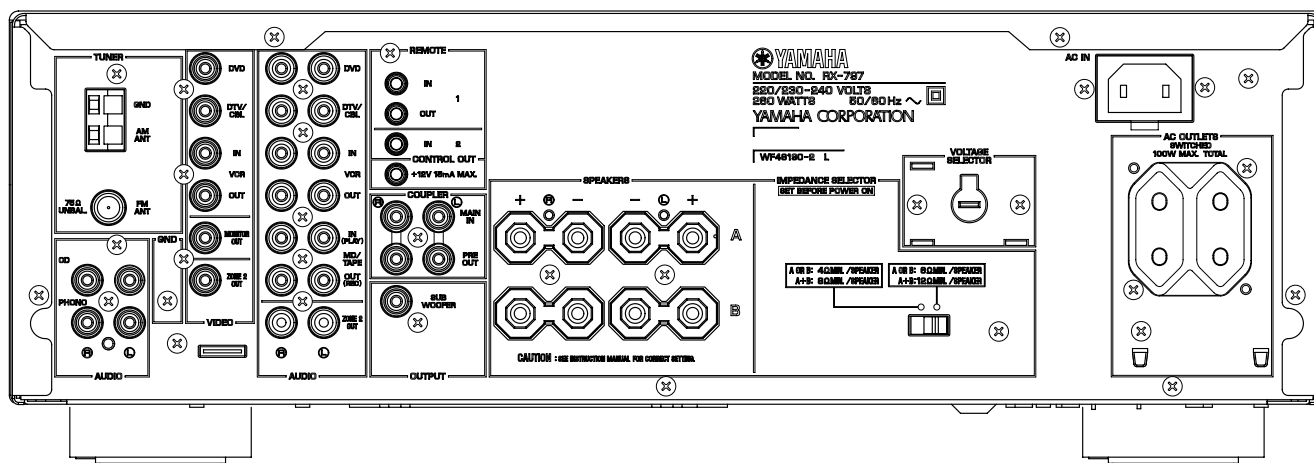

■ REMOTE CONTROL PANELS

▼ RAX100 (U, C models)

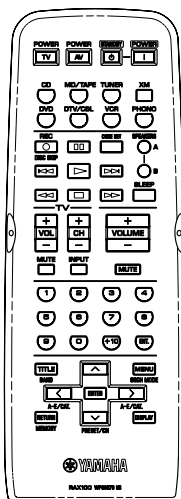

▼ RAX101 (R, A, G, E, L models)

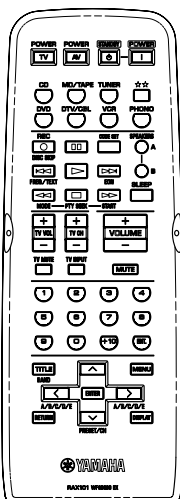

▼ RAX17 (U, C models)

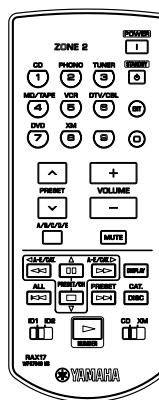

▼ RAX18 (R, A, G, E, L models)

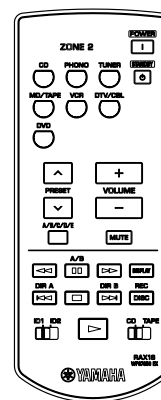

SPECIFICATIONS

AUDIO SECTION

Minimum RMS Output Power (Power Amp. Section)

L/R, 20 Hz to 20 kHz, 0.019% THD, 8 ohms 100 W + 100 W
L/R, 20 Hz to 20 kHz, 0.03% THD, 6 ohms 120 W + 120 W

Dynamic Power Per Channel (IHF)

8/6/4/2 ohms 140/170/220/290 W

Maximum Power Per Channel (G, E models)

1 kHz, 0.7 % THD, 4 ohms 160 W

IEC Power (G, E models)

1 kHz, 0.019% THD, 8 ohms 115 W

Maximum Power (EIAJ) (R, L models)

1 kHz, 10% THD, 8 ohms 145 W
1 kHz, 10% THD, 6 ohms 170 W

Power Band Width

L/R, 0.03% THD, 50 W, 8 ohms 10 Hz to 50 kHz

Damping Factor

20 Hz to 20 kHz, SPEAKER-A, 8 ohms 240 or more

Input Sensitivity/Input Impedance

PHONO MM 3.0 mV/47 k-ohms
CD, etc. 200 mV/47 k-ohms
MAIN IN 1 V/30 k-ohms

Maximum Input Signal

PHONO MM, 1kHz, 0.019 % THD 70 mV
CD, etc., 1kHz, 0.019 % THD 2.2 V

Output Level/Output Impedance

SUBWOOFER 4 V/1.2 k-ohms
PRE OUT 1 V/1.2 k-ohms
ZONE2 OUT 1 V/1.2 k-ohms
REC OUT 200 mV/1.2 k-ohms

Headphone Jack Rated Output/Output Impedance

CD, etc. 1 kHz, 200 mV, 8 ohms, 0.015% THD 0.47 V/470 ohms

Frequency Response

CD, etc. 20 Hz to 20 kHz 0 ± 0.5 dB
MAIN IN, 20 Hz to 20 kHz 0 ± 0.5 dB
CD, CD DIRECT AMP ON, 10 Hz to 100 kHz 0 ± 1.0 dB

RIAA Equalization Deviation

PHONO MM 0 ± 0.5 dB

Total Harmonic Distortion (20 Hz to 20 kHz)

PHONO MM to REC OUT (3 V) 0.008 % or less
CD, etc. to PRE OUT (1V) 0.007 % or less
CD, etc. to SP OUT (50 W/8 ohms) 0.012 % or less

Signal to Noise Ratio (IHF-A Network)

PHONO MM (Input shorted, 5 mV) 87 dB or more
CD, CD DIRECT AMP ON, (Input shorted, 200mV) 110 dB or more

Residual Noise (IHF-A Network)

CD DIRECT AMP ON 30 µV
PURE DIRECT ON 110 µV

Channel Separation

CD, etc. (Input 5.1 k-ohms shorted)
1 kHz 65 dB or more
10 kHz 50 dB or more

Tone Control Characteristics

BASS Boost/Cut (50 Hz) +10 dB/-10 dB
Turnover Frequency 350 Hz
TREBLE Boost/Cut (20 kHz) +10 dB/-10 dB
Turnover Frequency 3.5 kHz

Continuous Loudness Control

Attenuation (1 kHz) -30 dB

Gain Tracking Error

0 to -60 dB 2 dB or less

VIDEO SECTION

Video Signal Type

U, C, R models NTSC
A, G, E, L models PAL

Video Signal Level

..... 1 Vp-p/75 ohms

Video Maximum Input Level

..... 1.5 Vp-p or more

Video Signal to Noise Ratio

..... 50 dB or more

Monitor Out Frequency Response

..... 5 Hz to 10 MHz, -3 dB

FM SECTION

Tuning Range

U, C models 87.5 to 107.9 MHz
R, L models 87.5 to 108.0/87.50 to 108.00 MHz
A, G, E models 87.50 to 108.00 MHz

50 dB Quieting Sensitivity (IHF)

1 kHz 100% MOD.
Mono 2.0 µV (17.3 dBf)
Stereo 25 µV (39.2 dBf)

Usable Sensitivity (IHF)

Mono 1.0 µV (11.2 dBf)

Selectivity

at 400 kHz 70 dB

Signal to Noise Ratio (IHF)

Mono 76 dB
Stereo 70 dB

Harmonic Distortion (1 kHz)

Mono 0.2 %
Stereo 0.3 %

Stereo Separation (1 kHz)

..... 45 dB

Frequency Response

20 Hz to 15 kHz +0.5/-2.0 dB

Antenna Input

..... 75 ohms unbalanced

AM SECTION

Tuning Range

U, C models 530 to 1710 kHz
R, L models 530 to 1710/531 to 1611 kHz
A, G, E models 531 to 1611 kHz

Usable Sensitivity

..... 300 µV/m

Antenna

..... Loop antenna

GENERAL

Power Supply

U, C models AC 120 V, 60 Hz
R model AC 110/120/220/230-240 V, 50/60 Hz
A model AC 240 V, 50 Hz
G, E models AC 230 V, 50 Hz
L model AC 220/230-240 V, 50/60 Hz

Power Consumption

U, C models 260 W, 360 VA
R, A, G, E, L models 260 W

Standby Power Consumption (reference)

..... 0.1 W

Maximum Power Consumption (R model)

1 kHz, 6 ohms, 10% THD 650 W

AC Outlet

2 Switched Outlet
R model 50 W Max. total
U, C, G, E, L models 100 W Max. total
1 Switched Outlet
A models 100 W Max.

Dimensions (W x H x D) 435 x 151 x 389 mm
 (17-1/8" x 5-15/16" x 15-5/16")

Weight 10.9 kg (24 lbs)

Finish Black color (U, C, R, A, G, E, L models)
 Titanium color (G, E, L models)

Accessories Remote Control x 1
 Zone2 Remote Control x 1
 Battery (AA, R6, UM-3) x 2
 Battery (AAA, R03, UM-4) x 2
 Power Cable x 1
 Indoor FM Antenna x 1
 AM Loop Antenna x 1

* Specifications subject to change without notice.

U *USA model* **G** *European model*
C *Canadian model* **E** *South European model*
R *General model* **L** *Singapore model*
A *Australian model*



© 2005 XM Satellite Radio Inc. All rights reserved. All other trademarks are the property of their respective owners.

INTERNAL VIEW

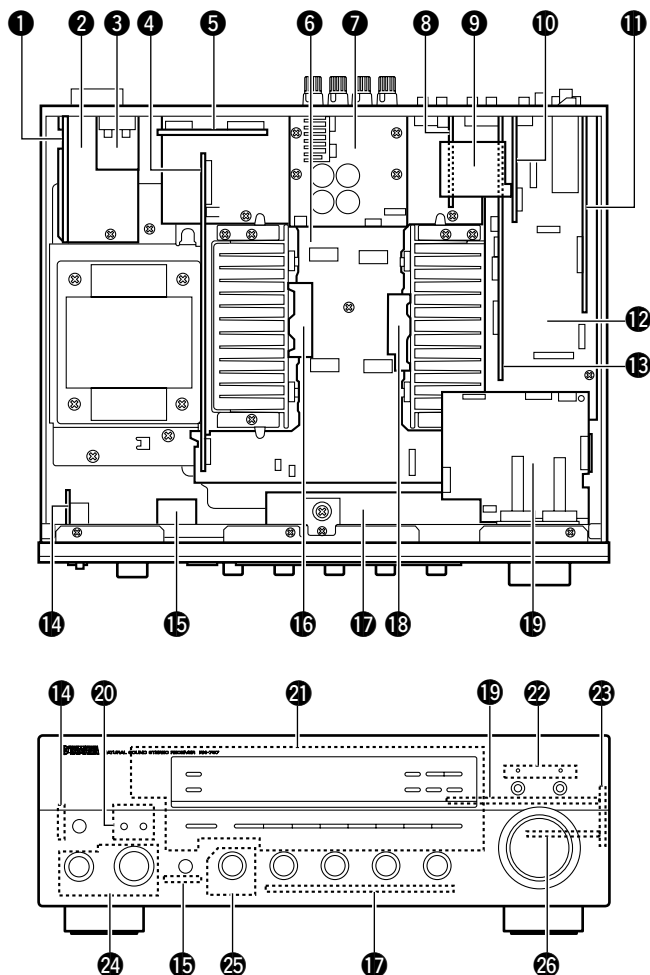

- 1 MAIN (2) P.C.B.
- 2 MAIN (3) P.C.B.
- 3 MAIN (8) P.C.B.
- 4 MAIN (4) P.C.B.
- 5 MAIN (5) P.C.B. (R, L models)
- 6 MAIN (1) P.C.B.
- 7 XM P.C.B. (U, C models)
- 8 FUNCTION (4) P.C.B.
- 9 FUNCTION (5) P.C.B.
- 10 FUNCTION (3) P.C.B.
- 11 OPERATION (13) P.C.B.
- 12 FUNCTION (2) P.C.B.
- 13 FUNCTION (1) P.C.B.
- 14 OPERATION (6) P.C.B.
- 15 OPERATION (10) P.C.B.
- 16 MAIN (7) P.C.B.
- 17 OPERATION (3) P.C.B.
- 18 MAIN (6) P.C.B.
- 19 OPERATION (2) P.C.B.
- 20 OPERATION (7) P.C.B.
- 21 OPERATION (1) P.C.B.
- 22 OPERATION (8) P.C.B.
- 23 OPERATION (9) P.C.B.
- 24 OPERATION (5) P.C.B.
- 25 OPERATION (11) P.C.B.
- 26 OPERATION (4) P.C.B.

DIMENSIONS

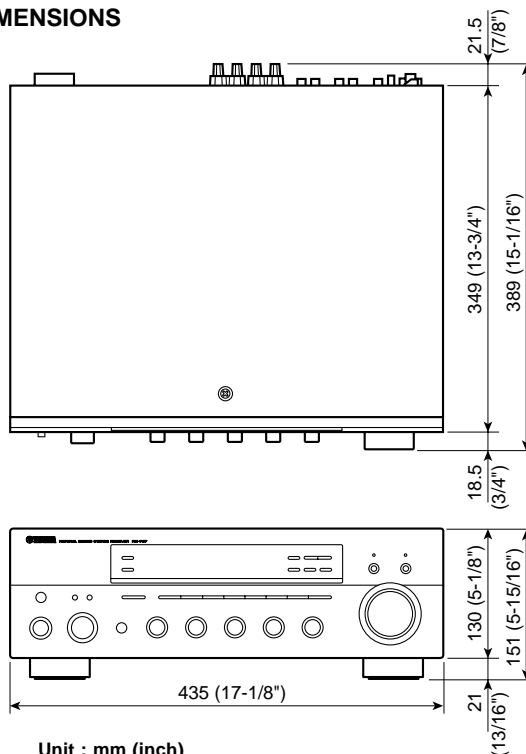

■ DISASSEMBLY PROCEDURES

- Remove parts in disassembly order as numbered.
- Disconnect the power cable from the AC outlet.

1. Removal of Top Cover

- Remove 4 screws (①), 1 screw (②) and 4 screws (③). (Fig. 1)
- Slide the Top Cover rearward to remove it. (Fig. 1)

2. Removal of Front Panel Unit

- Remove 6 knobs (INPUT, REC OUT, BASS, TREBLE, BALANCE, LOUNESS).
- Remove 1 screw (④) and then remove the Support Top. (Fig. 1)
- Remove 7 screws (⑤) and then remove the Front Panel Unit. (Fig. 1)

3. Removal of Plate Side

- Remove 2 push rivets (⑥) and then remove the Plate Side L/R. (Fig. 1)

4. Removal of Sub Chassis Unit

- Remove 2 screws (⑦) and then slide the Sub Chassis Unit forward. (Fig. 1)
- Loosen the harness fixture fixing the cable.
- Remove connectors CB283, CB401, CB404, CB407, CB503 and CB606 and then remove the Sub Chassis Unit. (Fig. 1)

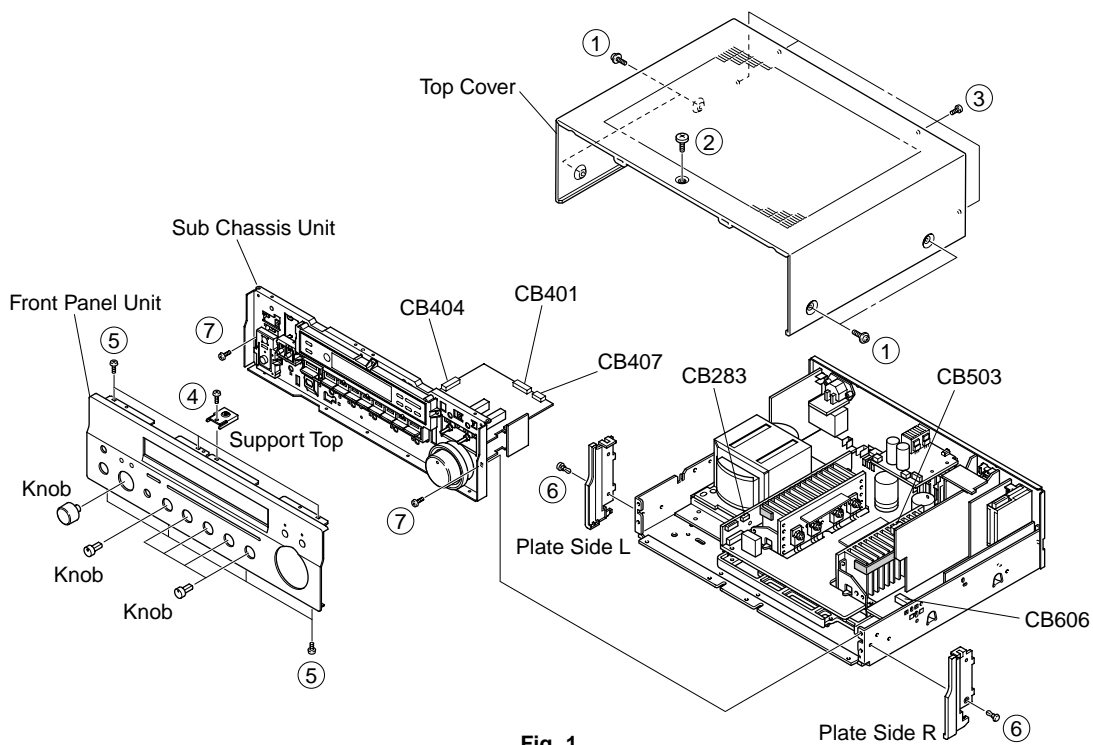

Fig. 1

■ SELF DIAGNOSIS FUNCTION

This product has a built-in self diagnosis function (DIAG) to facilitate inspection, measurement and determination of a faulty item, if any. There are 8 DIAG menu items, each having sub-menu items.

No.	DIAG menu	Sub-menu
1	DISPLAY CHECK	1. VFD CHECK (Initial display)
		2. VFD DISP OFF (All segments OFF)
		3. VFD DISP ALL (All segments ON 100%)
		4. VFD DIMMER (All segments ON 50%)
		5. CHECKED PATTERN (ON in lattice)
2	FACTORY PRESET	1. PRESET INHI (memory initialization inhibited)
		2. PRESET RSRV (memory initialized)
3	AD DATA CHECK	1. DC/PS (protection)
		2. THM L, R
		3. REC-OUT
		4. K0 / K1 (panel key)
4	XM STATUS	1. XMS1
		2. XMS2
5	PROTECTION SETTING	1. PS_Lo :
		2. PS_Hi :
		3. DC_Lo :
		4. DC_Hi :
		5. TEMP :
6	PROTECTION HISTORY	1. history 1
		2. history 2
		3. history 3
		4. history 4
7	SOFT SWITCH	1. SW MODE : PCB (/MODEL/FNC)
		2. MODEL SETTING : RX797 (/RX497/RX397)
		3. DESTINATION : UC (/RL/A/BG)
		4. TUNER DESTINATION : (/RL/ABG)
		5. TUNER TYPE : NRM (/RDS/XM)
		6. ZONE2 : EXIST (/NOT)
8	MICROPROCESSOR INFORMATION	1. VERSION
		2. CHECK SUM
		3. OPE / XM
		4. PORT
		5. EE SUM

● Starting DIAG

Press the "MASTER" key of the main unit while simultaneously pressing the "FM/AM" key and the "8" key to activate the DIAG function.

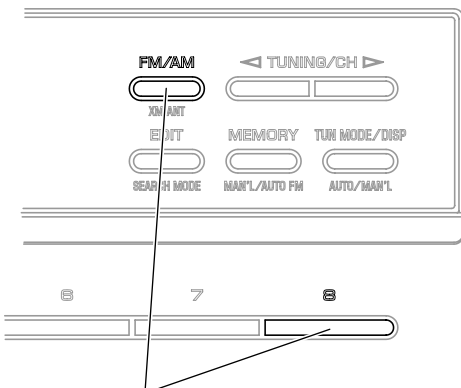

Turn on the power while pressing these keys.

● Starting DIAG in the protection cancel mode

If the protection function works and causing hindrance to trouble diagnosis, cancel the protection function as described below and it will be possible to enter the DIAG mode. (The protection functions other than the excess current detect function will be disabled.)

Press the "MASTER" key while simultaneously pressing those two keys indicated in the figure above. At this time, keep pressing those two keys for 3 seconds or longer.

In this mode, the "SLEEP" segment of the FL display of the main unit flashes to indicate that the mode is DIAG mode with the protection functions disabled.

CAUTION!

Using this product with the protection function disabled may cause damage to itself. Use special care for this point when using this mode.

● Canceling DIAG

1 Before canceling DIAG, execute setting for PRESET of DIAG menu No.2 (Memory initialization inhibited or Memory initialized).

* **In order to keep the user memory stored, be sure to select PRESET INHIBITED (Memory initialization inhibited). Protection history will remain in memory.**

2 Turn off the power by pressing the "MASTER" key of the main unit.

● Display provided when DIAG started

On the FL display of the main unit, an opening message (including the version and the protection history) appears for a few seconds followed by the diagnostic menu display (1. VFD CHECK).

When there is no history of protection function:

Opening message

When there is no protection history.

```
NO PROTECT Z
```

Version (1 alphabet)



After a few seconds.

DIAG menu display

```
1. VFD CHECK
```

When there is a history of protection function:

The FL display appears as shown below depending on the type of the protection function.

The protection function worked due to excessive current through the amplifier. The protection function activates immediately to turn off the power, with no history display at turn-on, if the amplifier is defective.

```
I PROTECT Z
```

The protection function worked due to a defect or overload in the power supply. The abnormal voltage is displayed in % based on 5V as 100%. If the power is turned on with the abnormality unsolved, the protection function works in about 1 second to turn off the power.

```
PS PRT :000 Z
```

The protection function worked due to a DC voltage appearing at the speaker terminal.

A cause could be a defect in the amplifier. If the power is turned on with the abnormality unsolved, the protection function works in about 3 seconds to turn off the power.



DC PRT :000 Z

The protection function worked due to the temperature limit being exceeded. Causes could be poor ventilation or a defect related to the thermal sensor. The abnormal voltage is displayed in % based on 5V as 500%. If the power is turned on with the abnormality unsolved, the protection function works in about 1 second to turn off the power.



TMR PRT:000 Z



TML PRT:000 Z

For detection of each protection function (except I-PROTECT) , refer to DIAG MENU No.3 AD DATA CHECK (p.13).

● History of protection function

When the protection function has worked, its history is stored in memory with a backup. Even if no abnormality is noted while servicing the unit, an abnormality which has occurred previously can be defined as long as the backup data has been stored.

The history of the protection function is cleared when DIAG is cancelled by selecting PRESET RESERVED (Memory initialized) of DIAG menu No.2 or when the backup data is erased.

● Display during menu operation

During the DIAG operation, the function at work is indicated on the FL indicator. The contents displayed during the function operation are described later in the “Details of DIAG menu” section.

● Operation procedure of DIAG MENU and SUB-MENU

There are 8 MENU items, each of which has some SUB-MENU items.

DIAG menu selection

Select the menu using PRESET NO keys.

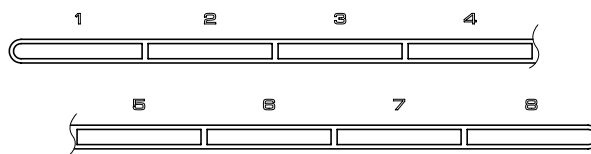

SUB-MENU selection

Select the sub-menu using ▷ (Forward) and ◁ (Reverse) keys of TUNING.

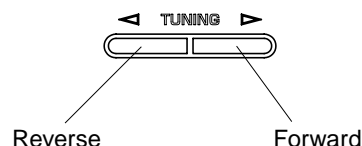

● Functions in DIAG mode

In addition to the DIAG menu items, functions as listed below are available.

- Input selection
- Muting
- Power on/off
- Master volume

* Functions related to the tuner is not available.

● Initial settings used to start DIAG

The following initial settings are used when starting DIAG. When DIAG is canceled, these settings are restored to those before starting DIAG.

- Input: DVD
- Audio mute: OFF
- DIAG menu: DISPLAY CHECK (1. VFD CHECK)

1. DISPLAY CHECK

This program is used to check the FL display section. The display condition varies as shown below according to the sub-menu operation.

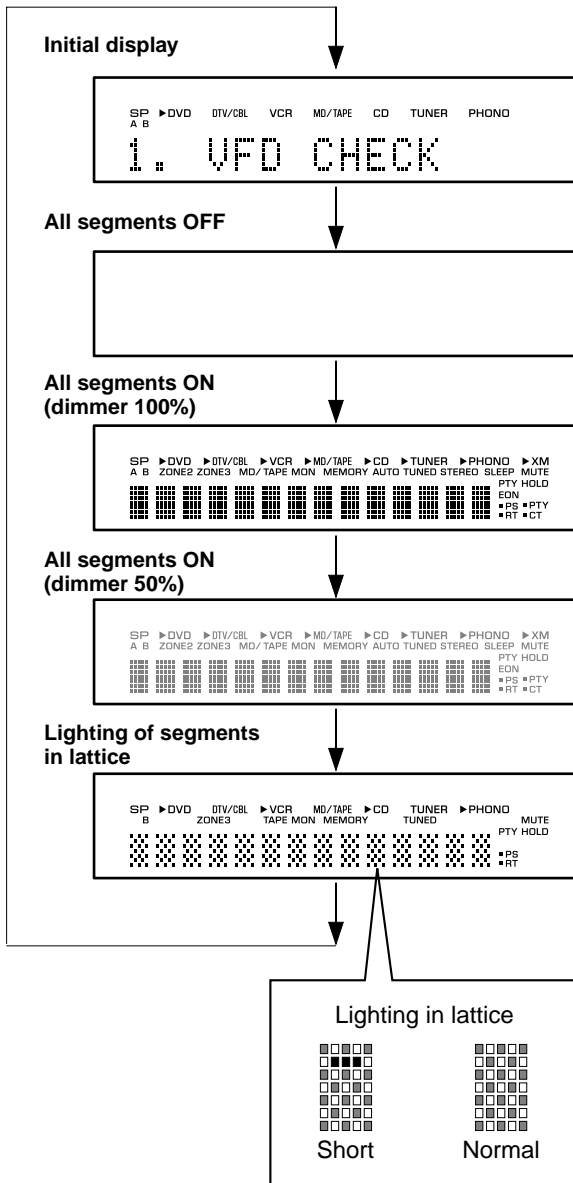

Segment conditions of the FL driver and the FL tube are checked by turning ON and OFF all segments. Next, the operation of the FL driver is checked by using the dimmer control. Then a short between segments next to each other is checked by turning ON and OFF all segments alternately (in lattice). (In the above example, the segments in the second row from the top are shorted.)

2. FACTORY PRESET

This menu is used to reserve/inhibit initialization of the back-up RAM.

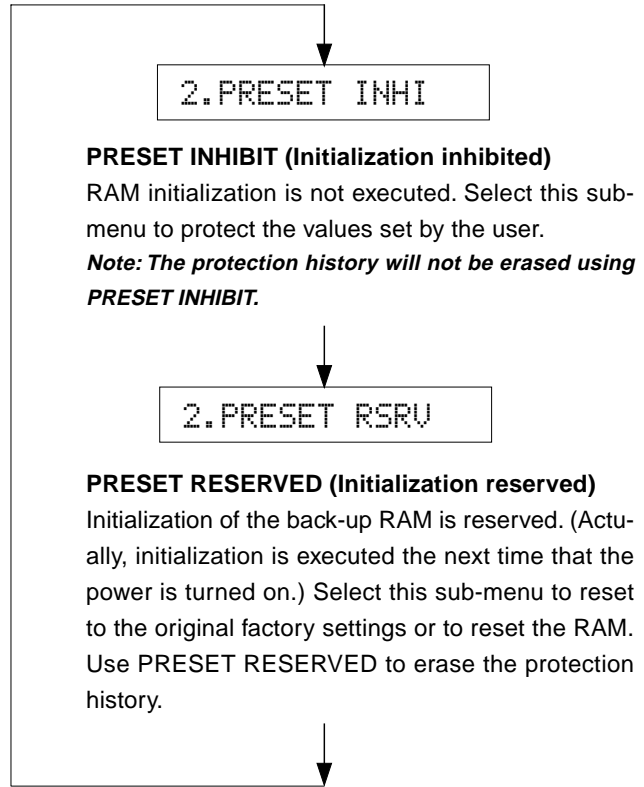

PRESET INHIBIT (Initialization inhibited)
RAM initialization is not executed. Select this sub-menu to protect the values set by the user.
Note: The protection history will not be erased using PRESET INHIBIT.

PRESET RESERVED (Initialization reserved)
Initialization of the back-up RAM is reserved. (Actually, initialization is executed the next time that the power is turned on.) Select this sub-menu to reset to the original factory settings or to reset the RAM. Use PRESET RESERVED to erase the protection history.

CAUTION: Before setting to the PRESET RESERVED, write down the existing preset memory content of the Tuner in a table as shown below. (This is because setting to the PRESET RESERVED will cause ALL user memory contents to be erased.)

Preset group	P1	P2	P3	P4
A				
B				
C				
D				
E				

Preset group	P5	P6	P7	P8
A				
B				
C				
D				
E				

● PRESET STATIONS

STATION		FM FACTORY PRESET DATA (MHz)	
PAGE	NO.	U, C	R, A, G, E, L
A/C/E	1	87.5	87.50
	2	90.1	90.10
	3	95.1	95.10
	4	98.1	98.10
	5	107.9	108.00
	6	88.1	88.10
	7	106.1	106.10
	8	107.9	108.00

STATION		AM FACTORY PRESET DATA (kHz)	
PAGE	NO.	U, C, R	A, G, E, L
B/D	1	630	630
	2	1080	1080
	3	1440	1440
	4	530	531
	5	1710	1611
	6	900	900
	7	1350	1350
	8	1400	1404

3. AD DATA CHECK

With this sub-menu used, the key scanning, A/D value of the voltage at the abnormality detect (protection) port, etc. are displayed. The A/D conversion value is displayed in %. The state before audio signal processing is kept.

When K0/K1 menu is selected, keys become nonoperable due to detection of the values of all keys.

However, it is possible to advance to the next sub-menu by turning the INPUT of the main unit. When using this function, note that turning the INPUT more than 2 clicks will cause the volume value to change.

** The numeric value in the diagram is for reference.*

DC/PS (protection detection)

DC: DC detect protection value

Normal value: 19 to 51 (Reference: 5V = 100%)

PS: Power supply voltage protection value

Normal value: 54 to 84 (Reference: 5V = 100%)

When the value is outside of the normal range, the protection function works to turn off the power.

DC:035 PS:067

THM (temperature detection)

When the value is outside of the normal range, the protection function works to turn off the power.

500% display of the voltage based on the temperature detected value. Reference voltage: 5V

THM:L096 R098

REC-OUT

255% display of the voltage based on the rec-out selector detected value. Reference voltage: 5V

For the correct value, refer to the table below.

REC-OUT:160

	%	U, C	R, A, G, E, L
1	22 – 46	DVD	DVD
2	47 – 75	DTC/CBL	DTV/CBL
3	76 – 105	VCR	VCR
4	106 – 135	MD/TAPE	MD/TAPE
5	136 – 166	CD	SOURCE
6	167 – 199	XM	CD
7	200 – 236	TUNER	TUNER
8	237 – 255	PHONO	PHONO

K0/K1

This is the A/D value of the panel key input ports KEY0 and KEY1 (microprocessor). The table below shows the A/D value obtained when each key is pressed. When the value is not within the standard value range, no correct operation is provided. Referring to the table below, check the value of each voltage dividing resistor of each key, solder condition, etc.

K0:100 K1:099

	%	Key0	Key1
1	0 – 4	FM/AM	P8
2	4 – 12	TUNING DOWN	P7
3	12 – 21	TUNING UP	P6
4	21 – 30	TUNING MODE	P5
5	31 – 41	MEMORY	P4
6	42 – 52	EDIT	P3
7	52 – 61	ZONE CTRL	P2
8	61 – 68	SPEAKER B	P1
9	68 – 74	SPEAKER A	A/B/C/D/E
10	75 – 81		
11	81 – 89		

4. XM STATUS

XM Radio data is displayed.

4. XMS1xxxxxxxx



4. XMS2xxxxxxxx

5. PROTECTION SETTING

This menu is used to change the protection setting value. The change is effective in this menu only. A set value can be specified between 0 – 255 (0V – 5V).

Operation:

Change the digit with the “EDIT” key.

UP / DOWN with the TUNING MODE / MEMORY key.

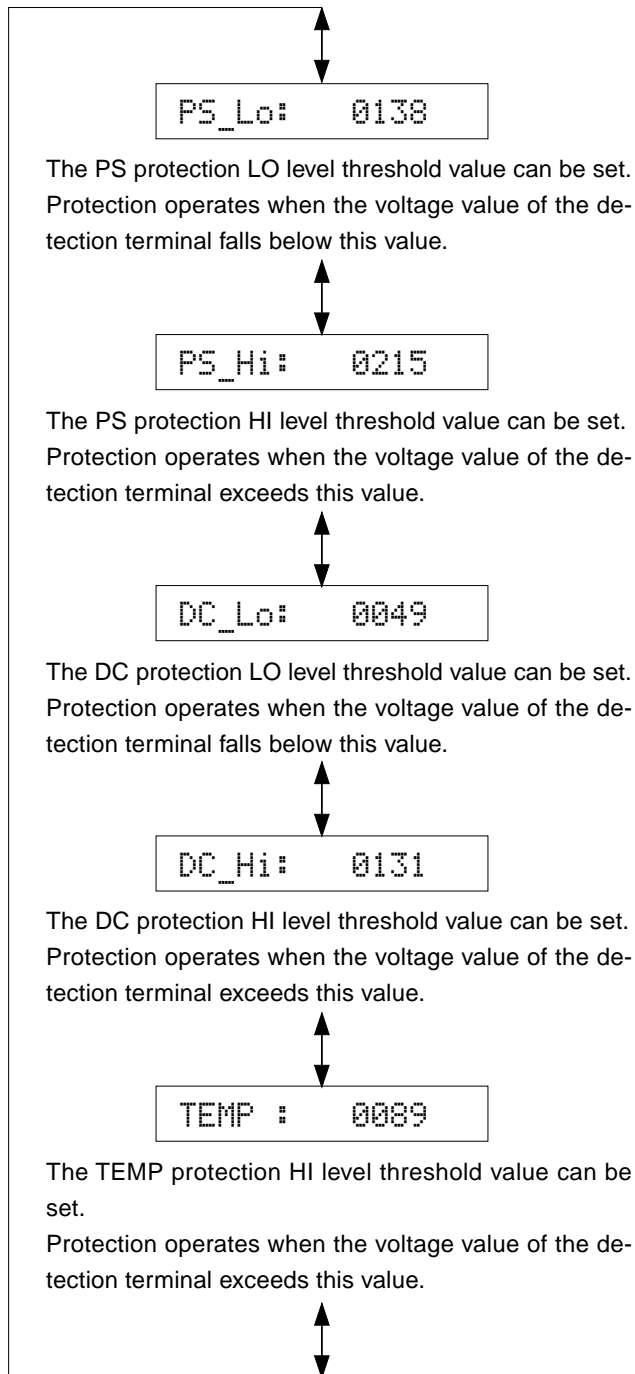

6. PROTECTION HISTORY

Four protection histories are displayed.

The history is cleared by the initialization reservation of DIAG menu No. 2.

When there is no history of protection function:

There is no history of protection function.

```
6-1 NoPRT
```

When there is a history of protection function:

There is a history of protection function due to excess current.

```
6-1 I PRT
```

There is a history of protection function due to abnormal voltage in the power supply section.

The abnormal voltage is displayed in % based on 5V as 100%.

```
6-2 PsPRT 069
```

There is a history of protection function due to abnormal DC output.

The abnormal voltage is displayed in % based on 5V as 100%.

```
6-3 DcPRT 059
```

There is a history of protection function excessive heatsink temperature. (R ch)

The abnormal voltage is displayed in % based on 5V as 500%.

```
6-4 TmRPRT 245
```

There is a history of protection function excessive heatsink temperature. (L ch)

The abnormal voltage is displayed in % based on 5V as 500%.

```
6-4 TmLPRT 245
```

**The numeric value in the diagram is for reference.*

7. SOFT SWITCH

Note) Changing the function setting may hinder the proper operation.

This menu is used to switch the function settings on P.C.B. through the software so as to activate the product.

The operation mode can be changed by selecting the sub-menu and then using the EDIT key.

The protection function follows the P.C.B. settings.

When connected to AC, the unit is initialized to the P.C.B. setting. Display of each function after initialization varies depending on settings on P.C.B.

SW MODE: PCB, MODEL or FNC can be selected.

7.SW :PCB

MODEL SETTING: RX797, RX497 or RX397 can be selected. (SW MODE: Selectable when MODEL has been selected.)

7.MODEL :RX797

DESTINATION: UC / RL / A or BGE can be selected. (SW MODE: Selectable when MODEL has been selected.)

7.DEST :UC

TUNER DEST INATION: UC, RL or ABGE can be selected. (SW MODE: Selectable when FNC has been selected.)

7.TuDest :UC

TUNER TYPE: NRM, RDS or XM can be selected. (SW MODE: Selectable when FNC has been selected.)

7.TuTyP :XM

ZONE2: NOT or EXIST can be selected. (SW MODE: Selectable when FNC has been selected.)

7.ZONE2 :EXIST

8. MICROPROCESSOR INFORMATION

The version, checksum and the port specified by the microprocessor are displayed. The checksum is obtained by adding the data at every 16 bits for each program area and expressing the result as a 4-figure hexadecimal data.

**The numeric value in the diagram is for reference.*

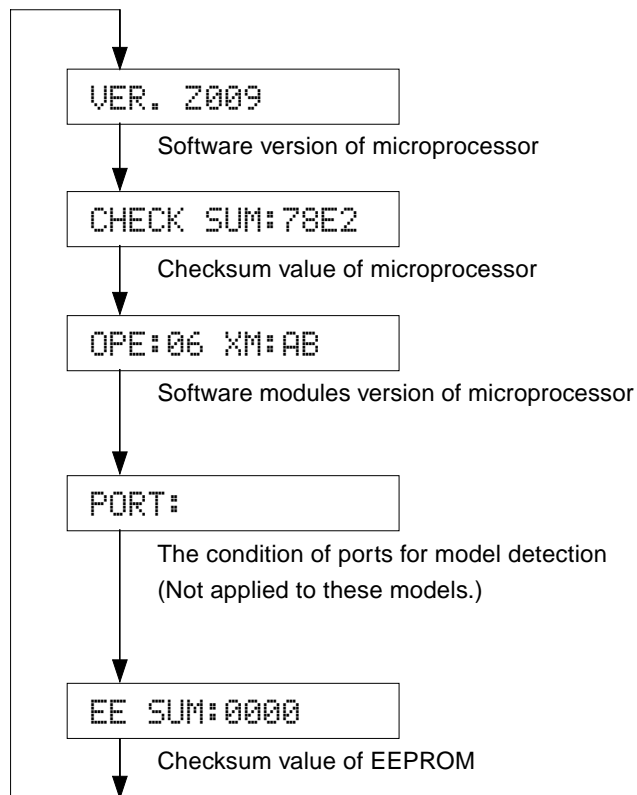

Tuner Dest	Frequency Range		Comment
	FM	AM	
UC	87.5-107.9MHz/200kHz	530-1710kHz/10kHz	
RL	87.5-108.0MHz/50kHz	531-1611kHz/9kHz	The frequency range is selected with Advanced Set Up
	87.5-108.0MHz/100kHz	530-1710kHz/10kHz	
ABG	87.5-108.0MHz/50kHz	531-1611kHz/9kHz	

■ AMP ADJUSTMENT

● CONFIRMATION OF IDLING CURRENT

1. Right after the power is turned on, confirm that the voltage across the terminals of R111–R135 (L ch) and R112–R136 (R ch) are between 0.1mV to 10.0mV.
2. If the measured voltage exceeds 10.0mV, open (cut off) R175 (L ch), R176 (R ch) and reconfirm the voltage.
3. Confirm that the voltage is between 0.20mV and 15.0mV after 60 minutes.

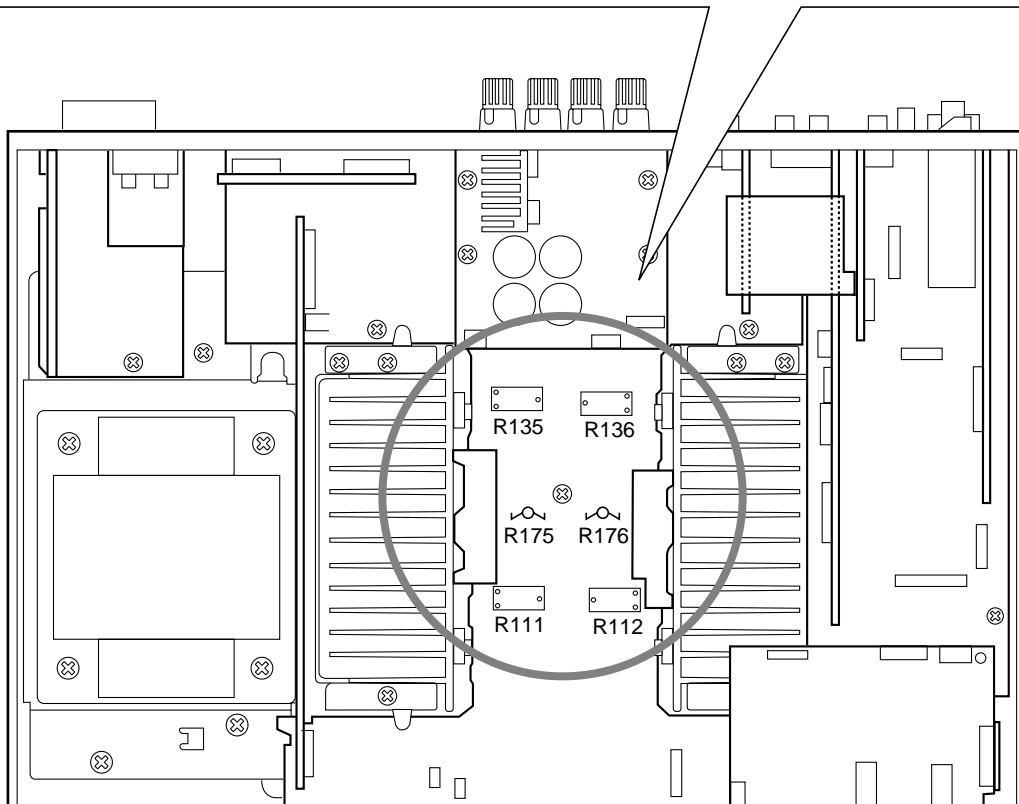
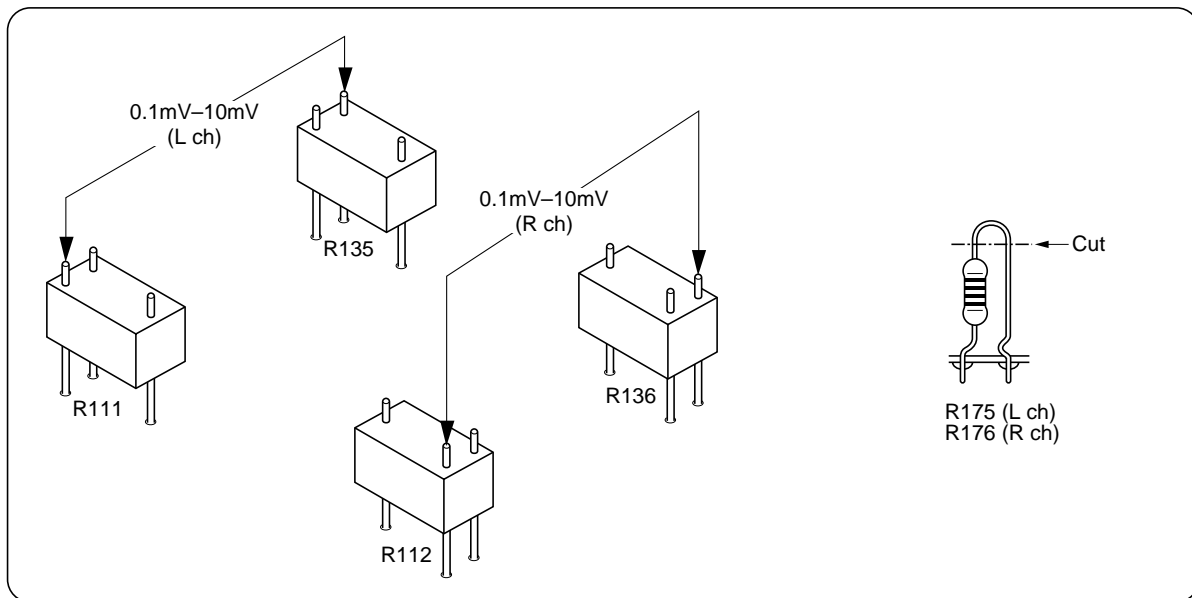

■ IC DATA

IC602 : M30626FHPFP (FUNCTION (2) P.C.B.)
16-bit Microprocessor

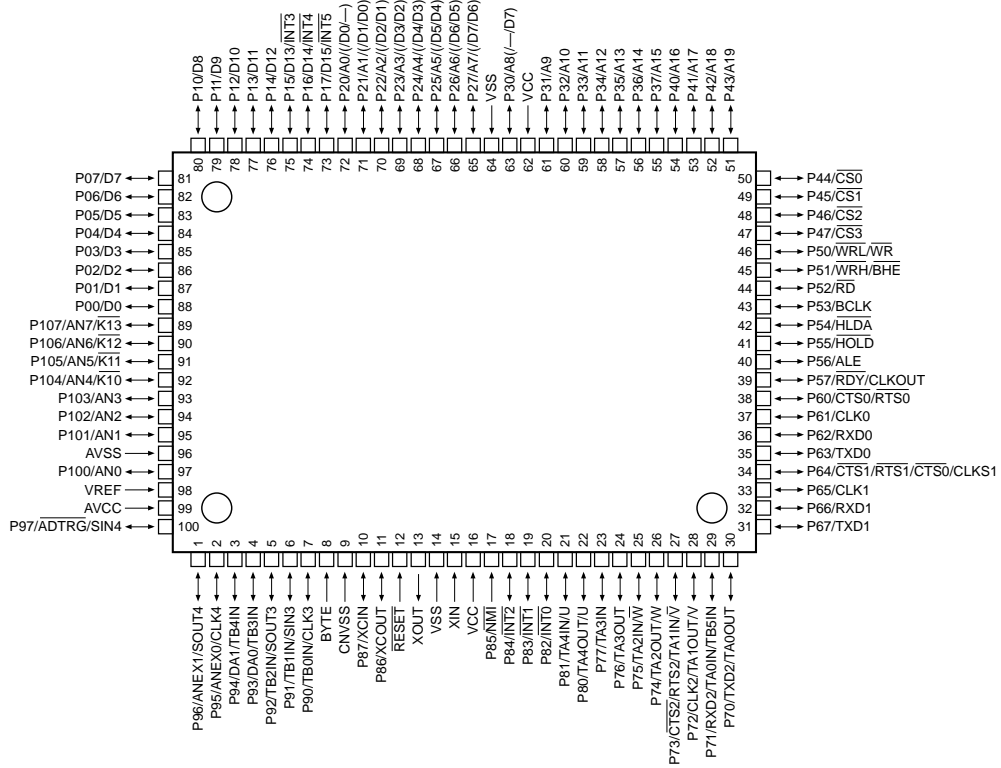

No.	Port	Name	I/O	Function
1	P96/ANEX1	DTFD	O	FL Driver Tx DATA
2	P95/ANEX0	CKFD	O	FL Driver CLOCK
3	P94		O	
4	P93	DEST1	I	Model Distinction 1
5	P92/TB2in	DEST0	I	Model Distinction 0
6	P91/TB1in	MOD1	I	Destination Distinction 1 (Reserve)
7	P90/TB0in	MOD0	I	Destination Distinction 0 (Reserve)
8	BYTE	BYTE	MCU	Vss: when single chip mode is used (Gnd)
9	CNVss	CNVss	MCU	Vss: when single chip mode is used, Vcc: when flash writing is used (PullDown)
10	P87/Xcin	/CEEEP	O	EEPROM CE
11	P86/Xcout	N.C.	O	
12	/RESET	/RESET	MCU	Reset
13	Xout	Xout	MCU	Oscillator Out
14	Vss	Vss	MCU	Ground (Gnd)
15	Xin	Xin	MCU	Oscillator In
16	Vcc1	Vcc	MCU	Power Supply, +5V (Vcc)
17	P85/NMI	NMI	I	Connect to Vcc because it is unused (PullUp)
18	P84/INT2	MPSW	IRQ	MAIN Power SW INT
19	P83/INT1	ZPSW	IRQ	Zone2 Power SW INT
20	P82/INT0	PDET	IRQ	Power Down Detect INT
21	P81	N.C.	O	(LevelConv)
22	P80	N.C.	O	(LevelConv)
23	P77	TRIG	O	Triger OUT
24	P76	/POMT	O	Pre Out Mute
25	P75/TA2in	/Z2MT	O	Zone2 Mute
26	P74/TA2out	N.C.	O	
27	P73/CTS2/RTS2/TA1in	XMPWR	O	XM/DT BUS POWER CONTROL
28	P72/CLK2/TA1out	/ICXM	O	DABIC IC Reset
29	P71/RXD2/SCL2/TA0in	DRXM	SI	DABIC IC RxD (LevelConv)
30	P70/TXD2/SDA2/TA0out	DTXM	SO	DABIC IC TxD (LevelConv)
31	P67/TXD1/SDA1	DTEV	SO	Zone2Volume Tx DATA(YAC526)
		TXDF	SO	Data Transmit Terminal for AF220
32	P66/RXD1/SCL1	CEEV	O	Zone2Volume CE(YAC526)
		RXDF	SO	Flash ROM RxD
33	P65/CLK1	CKEV	SO	Zone2Volume CLOCK(YAC526)
		CLKF	SO	Clock Transmit Terminal for AF220

IC602 : M30626FHPFP (FUNCTION (2) P.C.B.)
16-bit Microprocessor

No.	Port	Name	I/O	Function
34	P64/CTS1/RTS1/CTS0/CLKS1	BSY	O	AF220 BUSY Signal Output
35	P63/TXD0/SDA0	DTIS	SO	Input Selector Tx DATA
36	P62/RXD0/SCL0	CEIS	O	Input Selector CE
37	P61/CLK0	CKIS	SO	Input Selector CLOCK
38	P60/CTS0/RTS0	DTRZ	O	Rec/Zone2 selector DATA
39	P57/RDY/CLKout	CKRZ	O	Rec/Zone2 selector CLOCK
40	P56	N.C.	O	
41	P55	/EMP	I	For Flash Writing (LO) (PullDown)
42	P54	CER	O	RDS CE
43	P53	SCKR	O	RDS CLOCK
44	P52	SDRR	I	RDS Rx DATA
45	P51	SDTR	O	RDS Tx DATA
46	P50	/CE	I	For Flash Writing (HI) (PullUp)
47	P47	CEP	O	TUNER CE
48	P46	SCKP	O	TUNER CLOCK
49	P45	SDTP	O	TUNER Tx DATA
50	P44	/TMU	O	TUNER MUTE
51	P43	SDRP	I+	TUNER Rx DATA
52	P42	TUNED	I+	TUNER TUNED
53	P41	/ST	I+	TUNER /ST
54	P40	N.C.	O	
55	P37	VIA	O	Video Input SelectorA (PullDown)
56	P36	VIB	O	Video Input SelectorB (PullDown)
57	P35	VRA	O	Video Rec SelectorA (PullDown)
58	P34	VRB	O	Video Rec SelectorB (PullDown)
59	P33	VZA	O	VIDEO Zone2 SelectorA
60	P32	VZB	O	VIDEO Zone2 SelectorB
61	P31	/SWMT	O	Sub Woofer Mute
62	Vcc2	Vcc	MCU	Power Supply, +5V (Vcc)
63	P30	/CDMT	O	CD Direct Mute
64	Vss	Vss	MCU	Ground (Gnd)
65	P27	/MIMT	O	Main IN Mute
66	P26	PDon	I+	Pure Direct ON Detect
67	P25	CDOn	I+	CD Direct Detect
68	P24	PLED	O	Pure Direct LED
69	P23	CLED	O	CD Direct/TapeMonitor LED
70	P22	PRY	O	Power Relay
71	P21	N.C.	O	
72	P20	HPRY	O	Head Phone Relay
73	P17	PDET	IRQ	Power Down Detect INT
74	P16	SPSW	IRQ	SYSTEM Power SW INT(MasterPower)
75	P15	REM	IRQ	Remote Controler INT
76	P14	FBRY	O	Front B Speaker Relay
77	P13	FARY	O	Front A Speaker Relay
78	P12	VRup	O	Volume Up
79	P11	VRdn	O	Volume Down
80	P10	PRI	I	I Protection
81	P07	/PSV	O	Power save mode
82	P06	N.C.	O	
83	P05	/BLK	O	FL Driver /BLK
84	P04	ISA	I	Input Selector A (PullUp)
85	P03	ISB	I	Input Selector B (PullUp)
86	P02	LSBY	O	StandBy LED
87	P01	N.C.	O	
88	P00	N.C.	O	
89	P107/AN7/K13	REC	AD	Rec/Zone2 selector
90	P106/AN6/K12	PRV	AD	PS Protection (PullUp)
91	P105/AN5/K11	PRD	AD	DC Protection (PullUp)
92	P104/AN4/K10	THML	AD	THM L Protection (PullUp)
93	P103/AN3	THMR	AD	THM R Protection (PullUp)
94	P102/AN2	KEY0	AD	AD Key 0
95	P101/AN1	KEY1	AD	AD Key 1
96	Avss	Avss	MCU	AD Ground (Gnd)
97	P100/AN0	DEST	AD	Destination Detect
98	Vref	Vref	MCU	AD Reference (Vcc)
99	Avcc	Avcc	MCU	AD Power Supply (Vcc)
100	P97/Adtrg	CEFD	O	FL Driver CE

DISPLAY DATA

V801 : 15-BT-105GNK (WF519900)

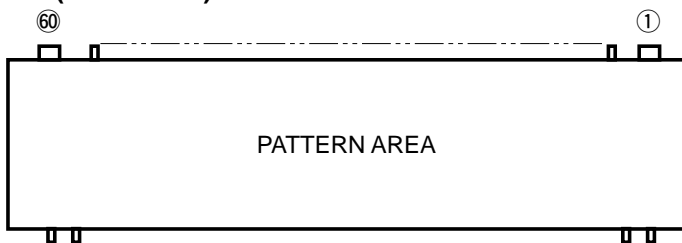

PIN CONNECTION

PIN NO.	54444444443333333322222222111111111111
CONNECTION	P N N 5 4 3 2 1 0 9 8 7 6 5 4 3 2 1 0 9 8 7 6 5 4 3 2 1 0 9 8 7 6 5 4 3 2 1

PIN NO.	65555555
CONNECTION	F N N N N P P P P P P 2 X P P 1 2 3 4 5 6

- Note**
- 1) F1, F2 Filament
 - 2) NP No Pin
 - 3) NX No Extend Pin
 - 4) P1~P35 Datum Line
 - 5) 1G~15G Grid

GRID ASSIGNMENT

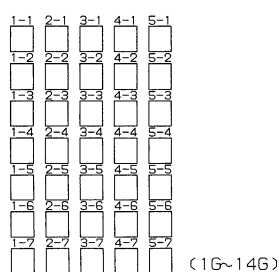
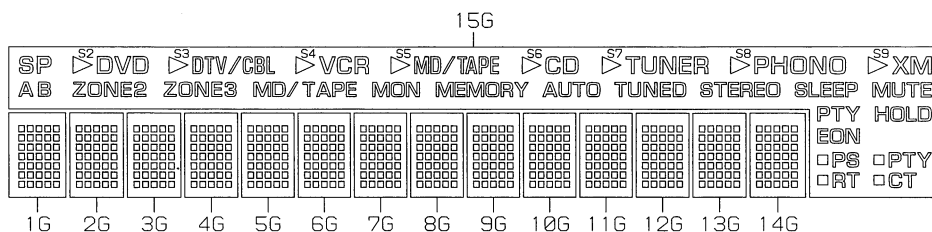

- S10 □ □ S11
S12 □ □ S13
(15G)

ANODE CONNECTION

	1G~14G	15G
P1	1-1	SP
P2	2-1	A
P3	3-1	B
P4	4-1	ZONE2
P5	5-1	ZONE3
P6	1-2	MD/
P7	2-2	TAPE MON
P8	3-2	AUTO
P9	4-2	TUNED
P10	5-2	STEREO
P11	1-3	MEMORY
P12	2-3	SLEEP
P13	3-3	PTY HOLD
P14	4-3	EON
P15	5-3	S10
P16	1-4	S11
P17	2-4	S12
P18	3-4	S13
P19	4-4	PS
P20	5-4	PTY
P21	1-5	RT
P22	2-5	CT
P23	3-5	S2
P24	4-5	S3
P25	5-5	S4
P26	1-6	S5
P27	2-6	S6
P28	3-6	S7
P29	4-6	S8
P30	5-6	S9
P31	1-7	S1
P32	2-7	XM
P33	3-7	MUTE
P34	4-7	-
P35	5-7	-

RX-797

PRINTED CIRCUIT BOARD

XM P.C.B.

(Side A) Lead Free Solder Used

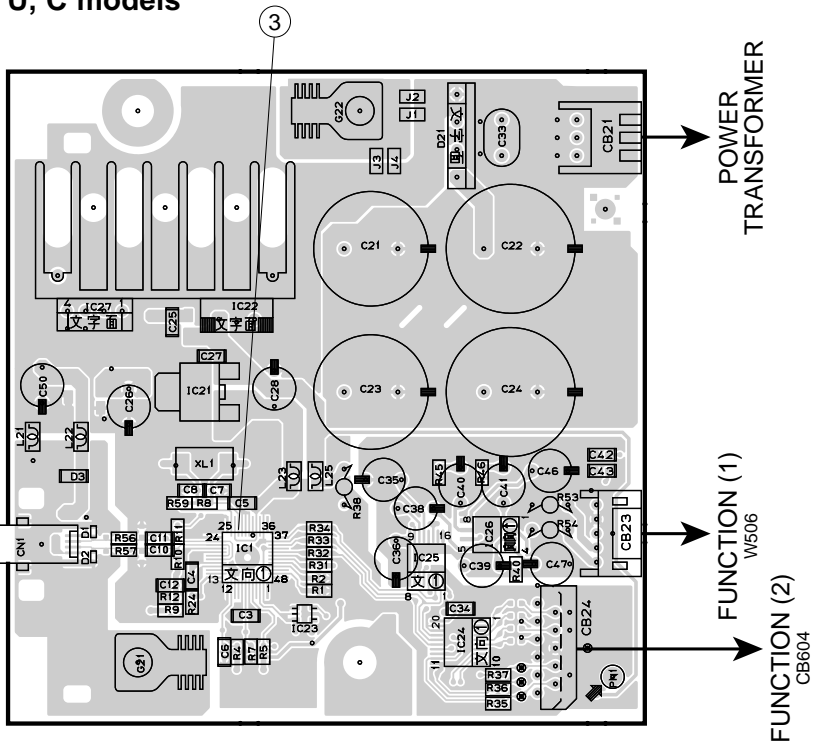
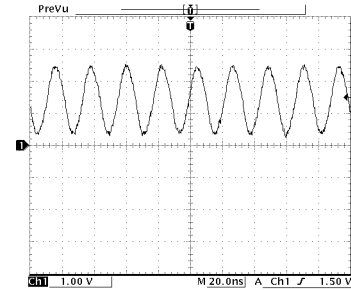
U, C models

Point ③ (Pin 28 of IC1)

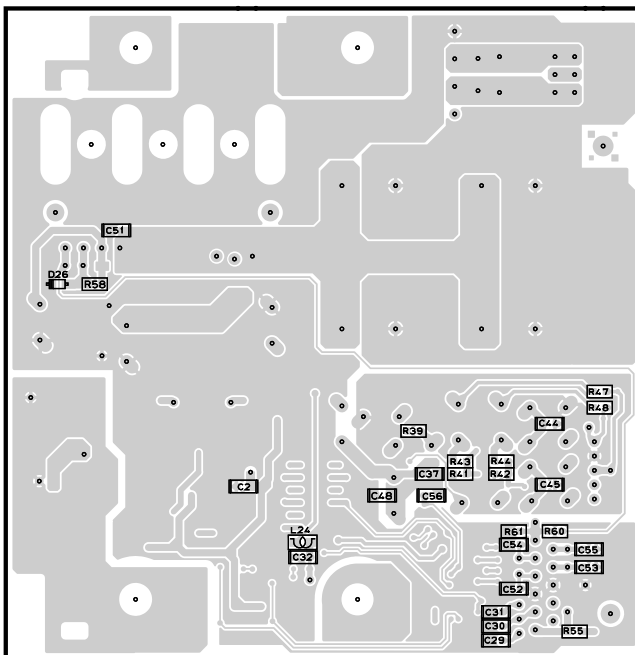
XM P.C.B.

(Side B) Lead Free Solder Used

U, C models

PRINTED CIRCUIT BOARD

1

FUNCTION (1) P.C.B. (Side A)

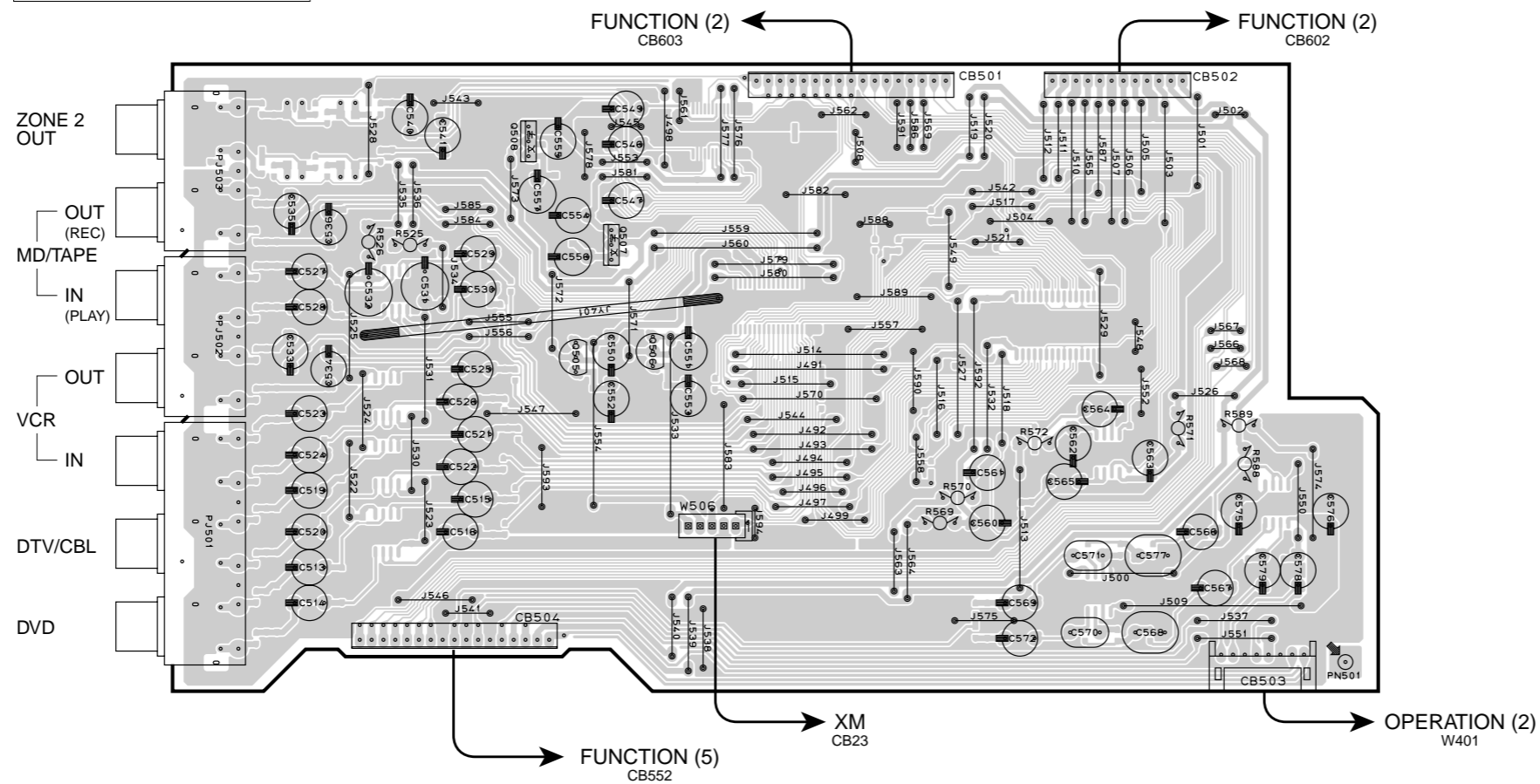

2

3

FUNCTION (1) P.C.B. (Side B) Lead Free Solder Used

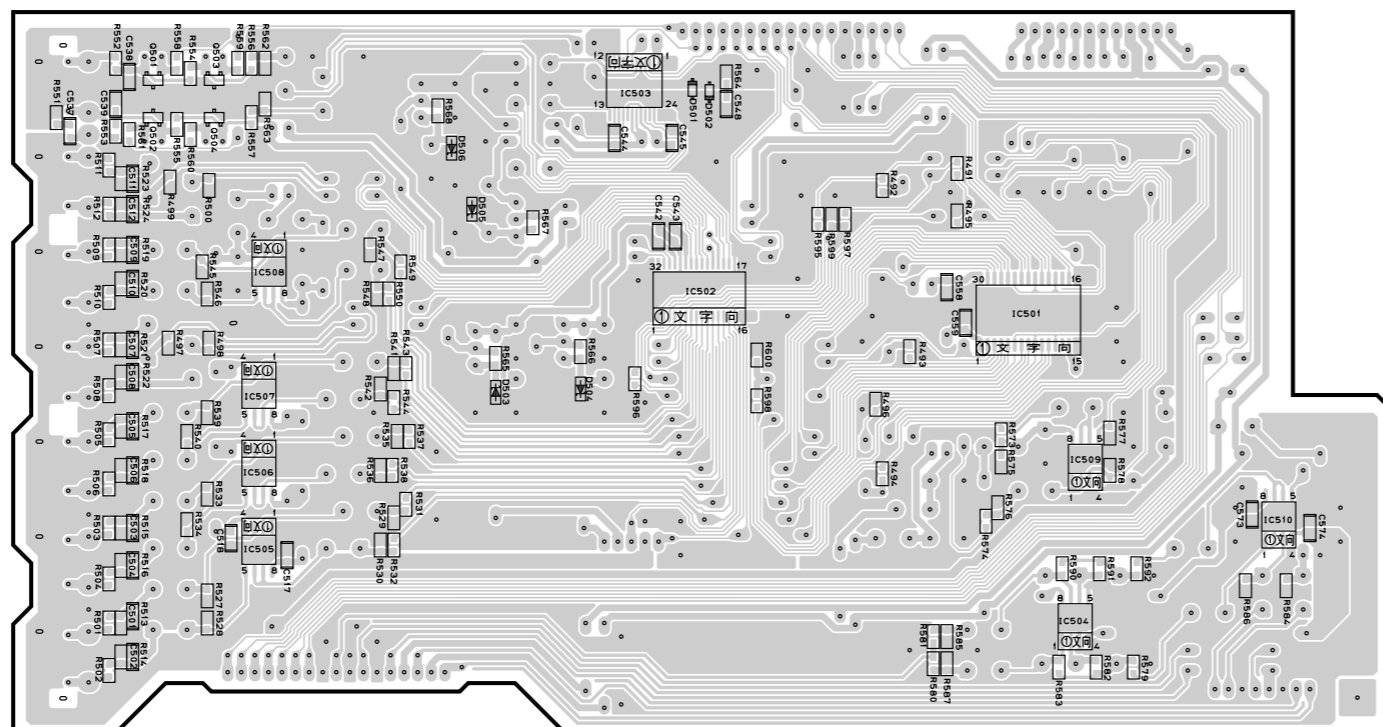

4

5

6

FUNCTION (1)

Circuit No.	U, C	R, L	A	G, E
W506	O	X	X	X

X: NOT USED

O: USED/APPLICABLE

PRINTED CIRCUIT BOARD

FUNCTION (2) P.C.B. (Side A)

FUNCTION (2) P.C.B. (Side B) Lead Free Solder Used

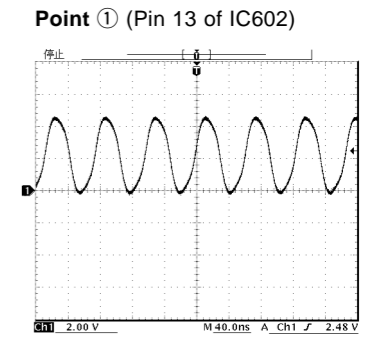
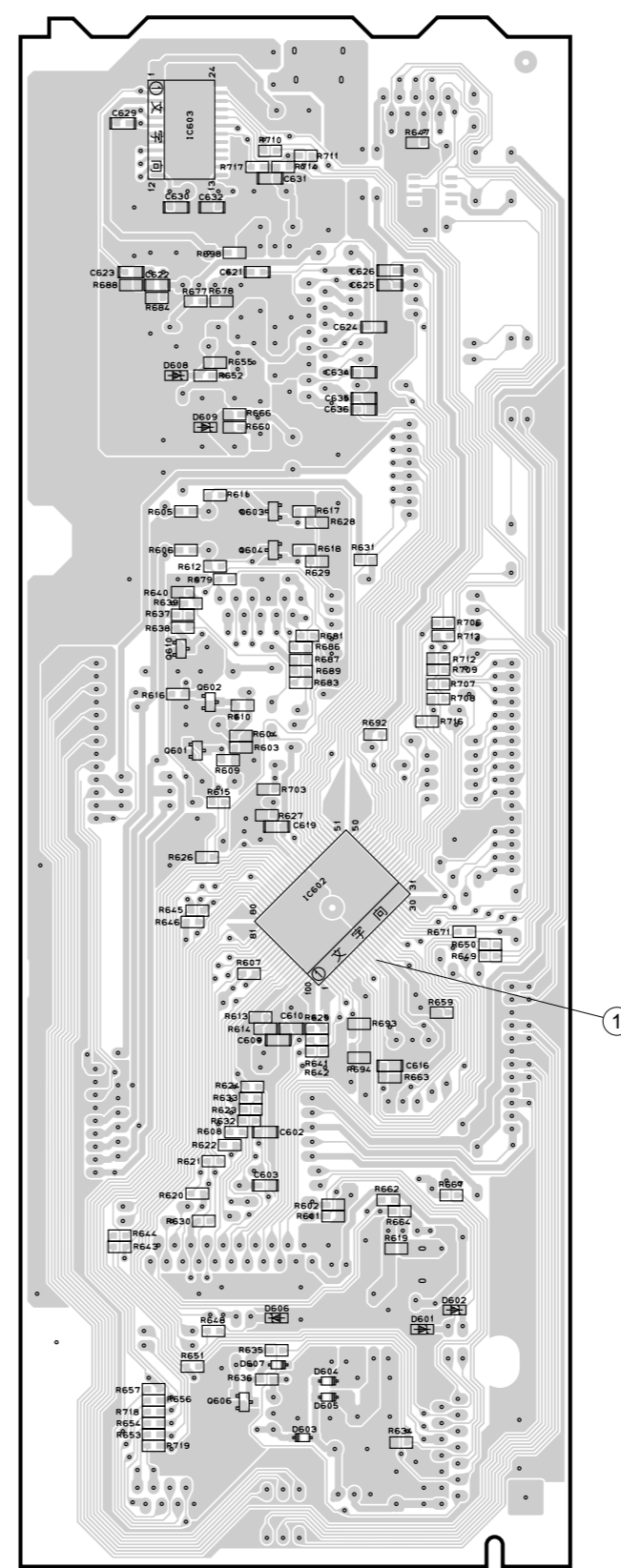
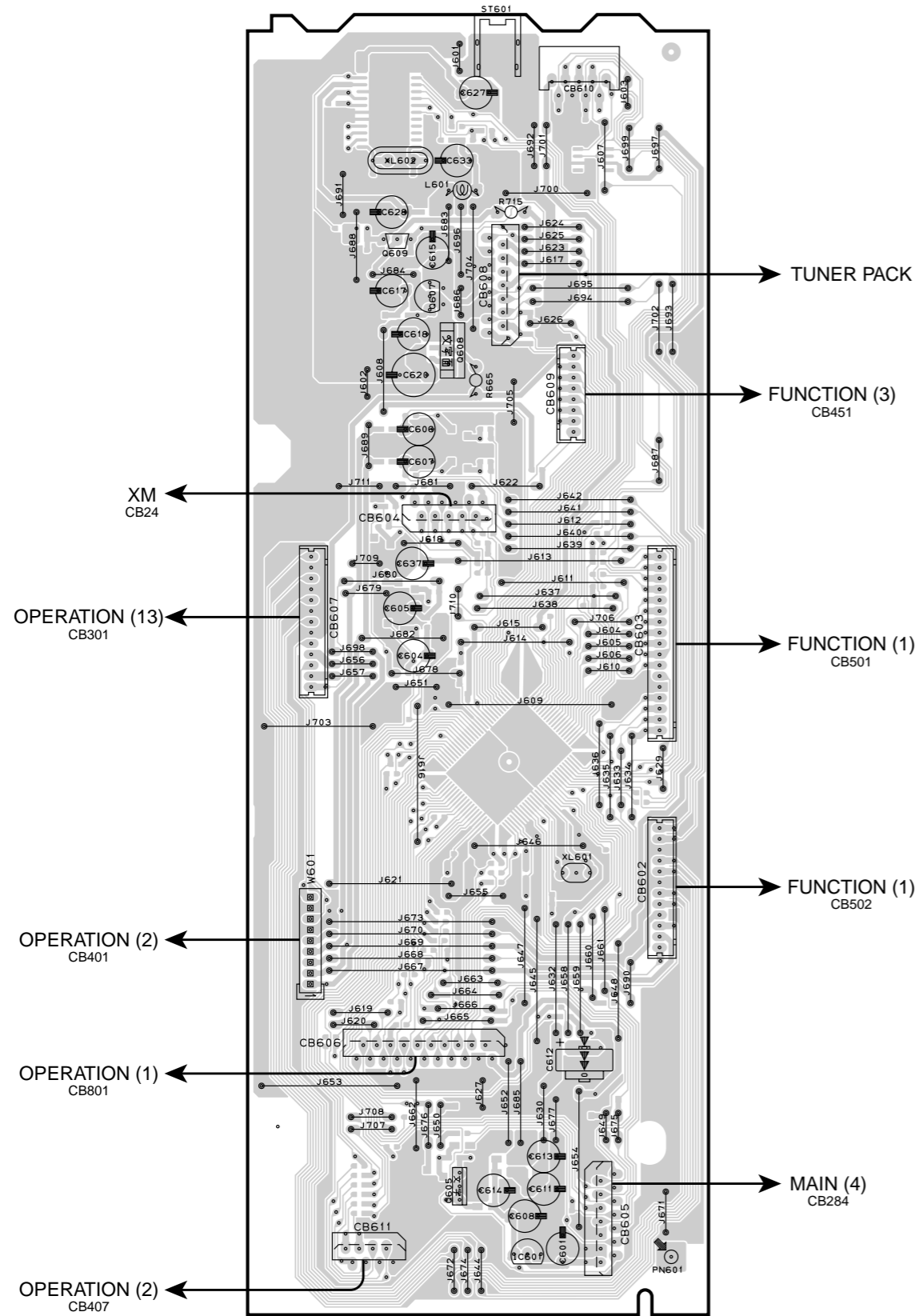

FUNCTION (2)

Circuit No.	U, C	R, L	A	G, E
CB604	O	X	X	X
R679, 681, 683, 686	O	X	X	X
R687, 688	O	X	X	X
R601	X	O	O	O
IC603	X	X	X	O
XL602	X	X	X	O
C630, 632	X	X	X	O
C622, 623	X	X	X	O
C629	X	X	X	O
C621, 631	X	X	X	O
C627, 628, 633	X	X	X	O
R698	X	X	X	O
R710, 711	X	X	X	O
R684	X	X	X	O
R714, 717	X	X	X	O
R688	X	X	X	O
R678	X	X	X	O
R677	X	X	X	O
L601	X	X	X	O
Q609	X	X	X	O

X: NOT USED
O: USED/APPLICABLE

PRINTED CIRCUIT BOARD

1

FUNCTION (3) P.C.B. (Side A)

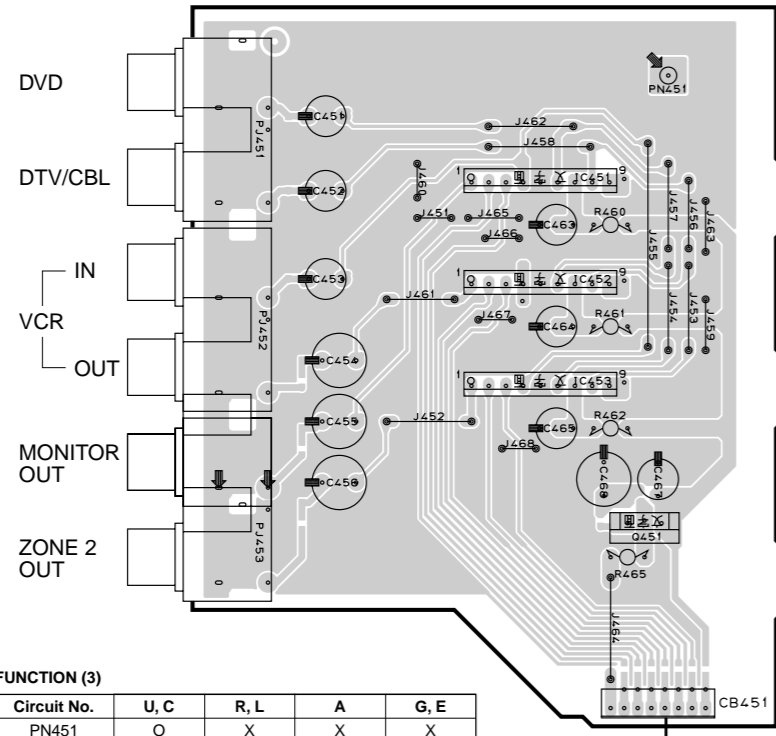

Circuit No.	U, C	R, L	A	G, E
PN451	O	X	X	X

X: NOT USED
O: USED/APPLICABLE

FUNCTION (2)
CB609

FUNCTION (3) P.C.B. (Side B) Lead Free Solder Used

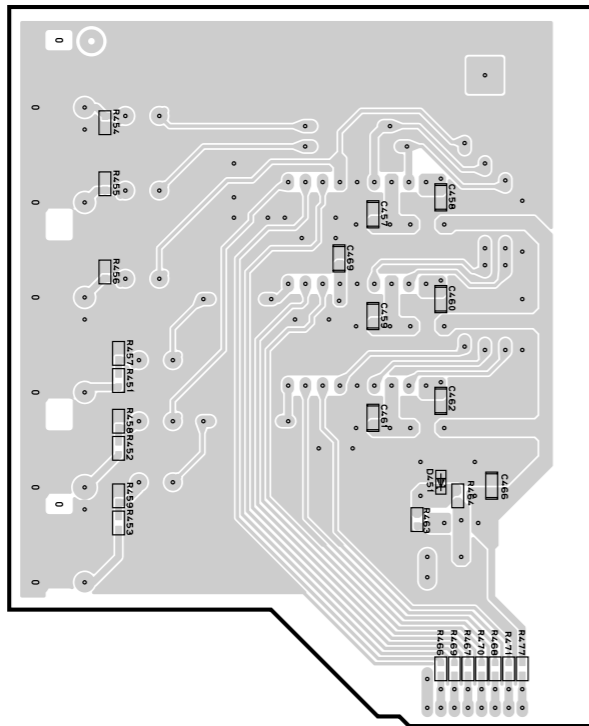

4

5

6

FUNCTION (4) P.C.B. (Side A)

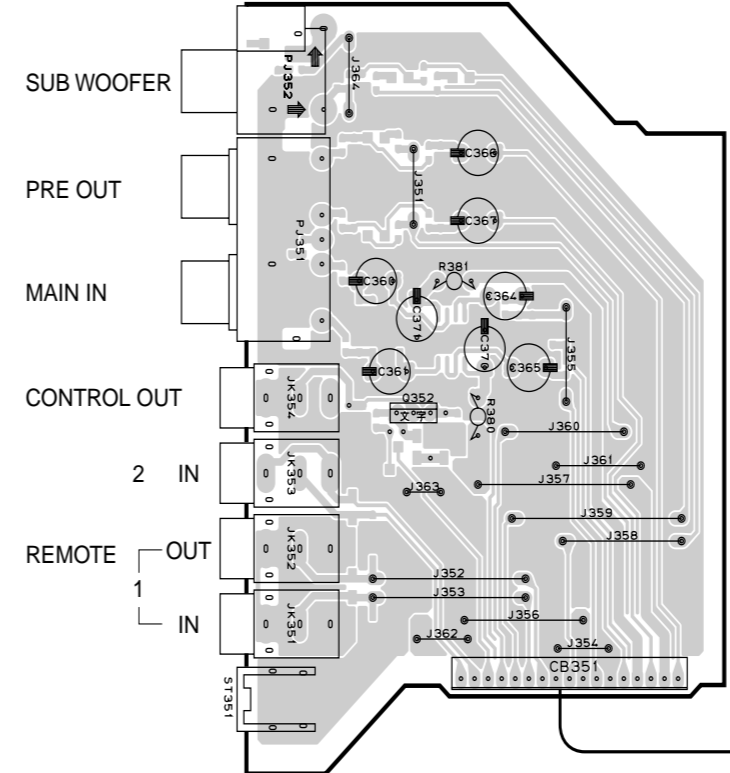

FUNCTION (4) P.C.B. (Side B) Lead Free Solder Used

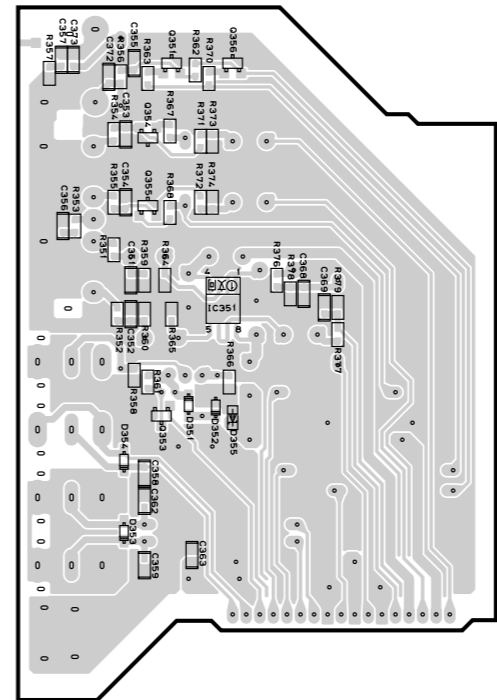

FUNCTION (5) P.C.B. (Side A)

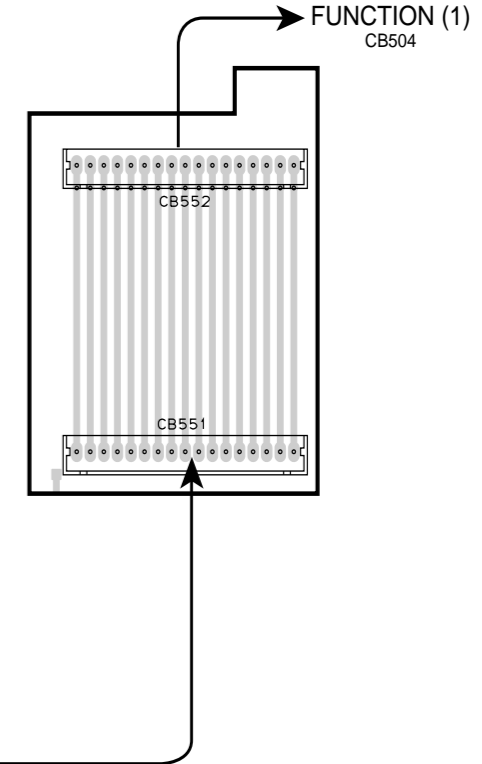

PRINTED CIRCUIT BOARD

OPERATION (1) P.C.B. (Side A)

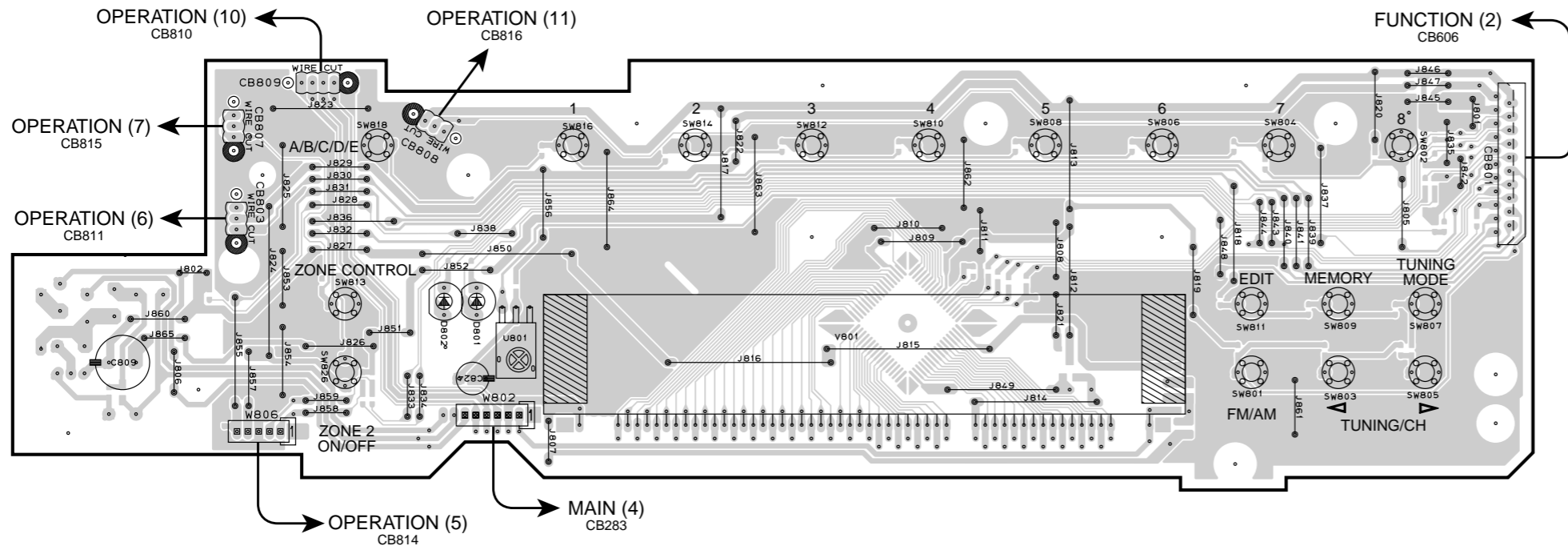

OPERATION (4) P.C.B. (Side A)

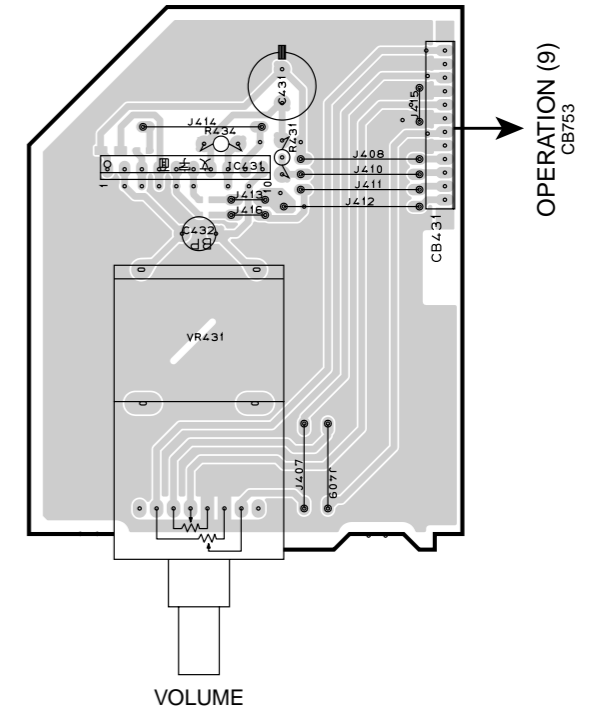

OPERATION (1) P.C.B. (Side B) Lead Free Solder Used

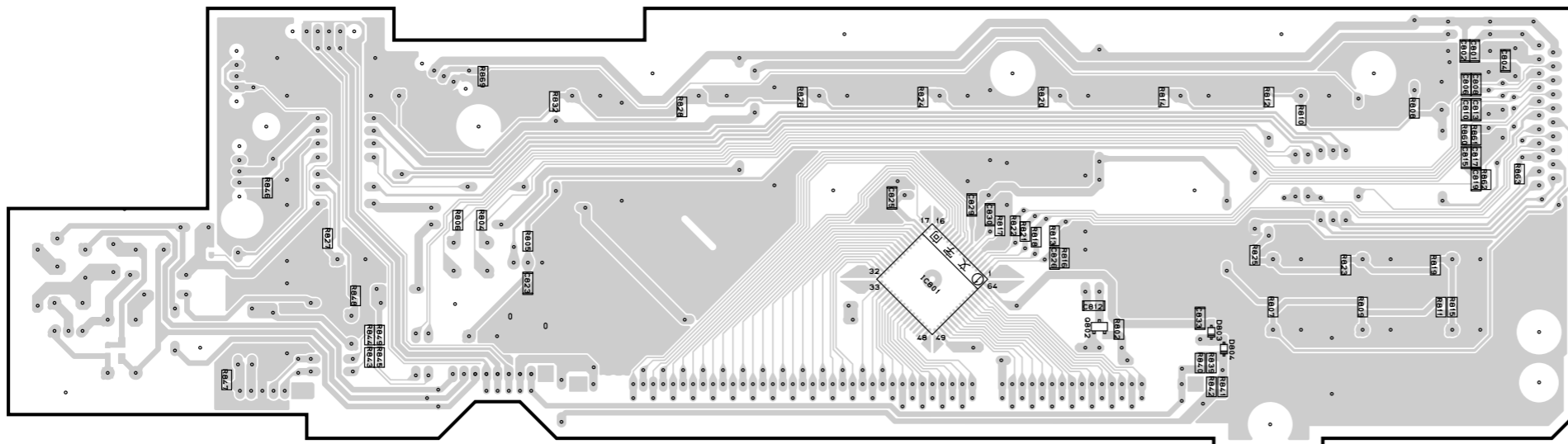

OPERATION (4) P.C.B. (Side B) Lead Free Solder Used

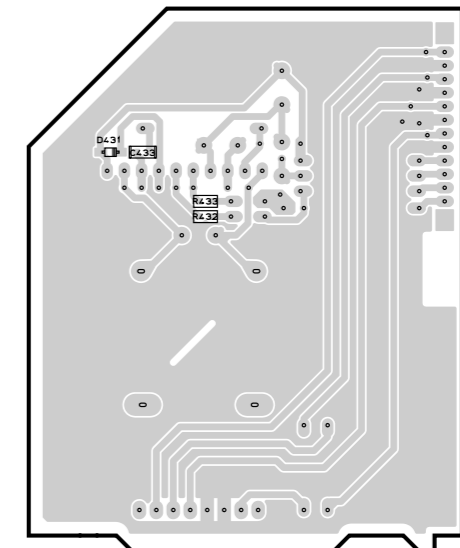

PRINTED CIRCUIT BOARD

1

OPERATION (2) P.C.B. (Side A)

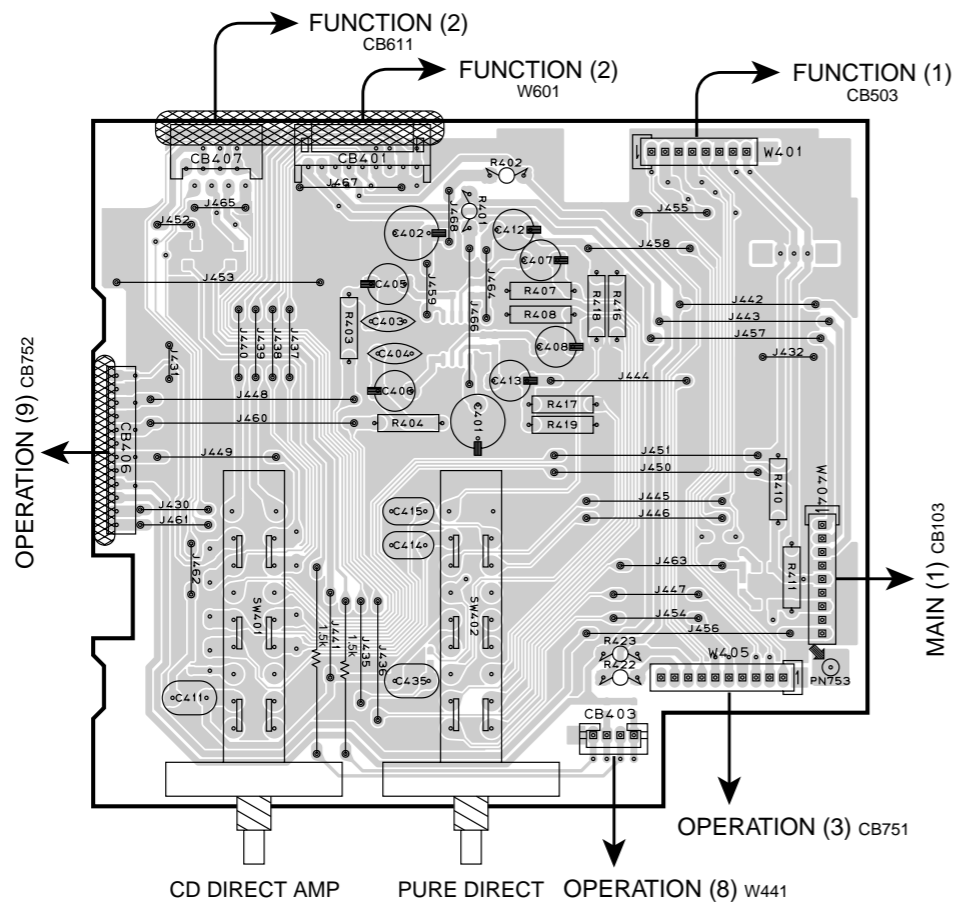

2

3

4

OPERATION (2) P.C.B. (Side B) Lead Free Solder Used

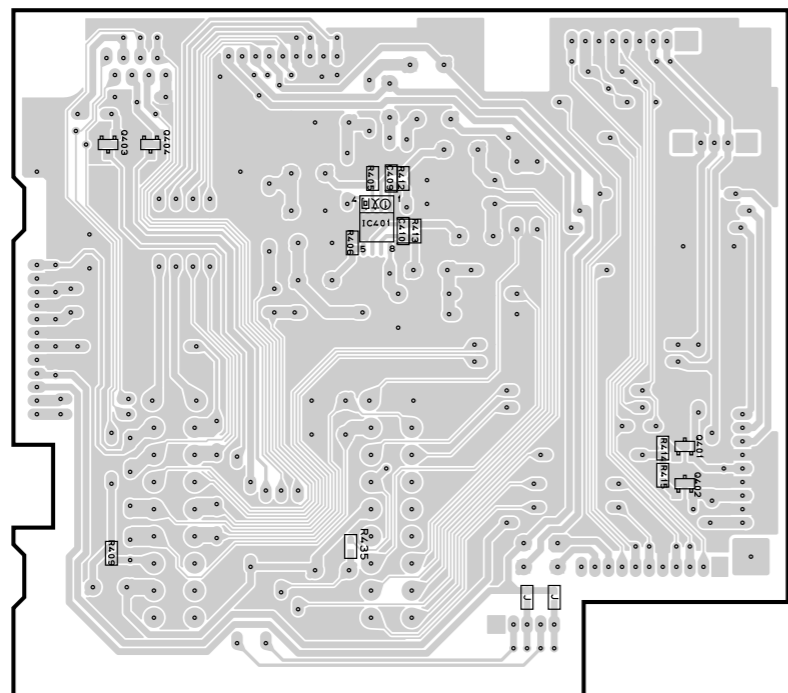

5

6

OPERATION (3) P.C.B. (Side A)

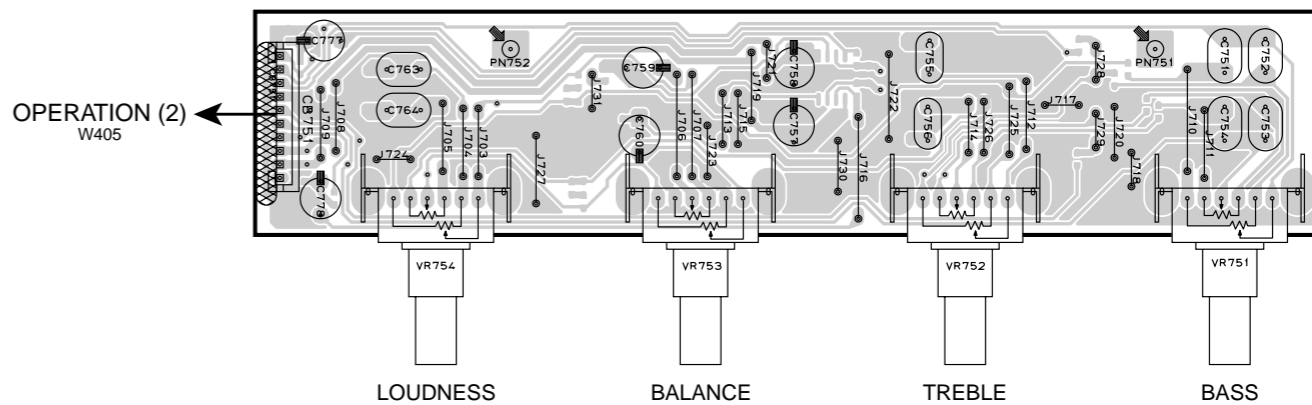

OPERATION (3) P.C.B. (Side B) Lead Free Solder Used

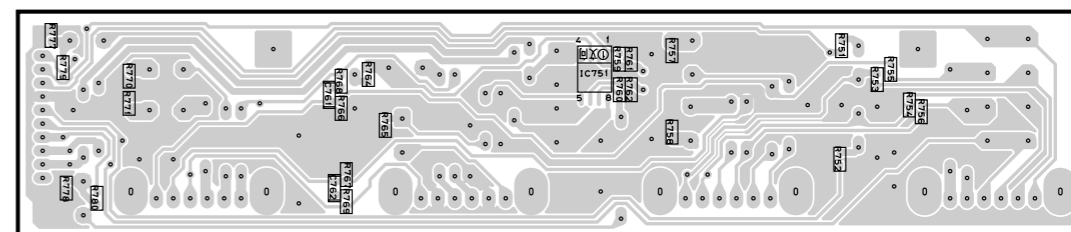

OPERATION (5) P.C.B. (Side A)

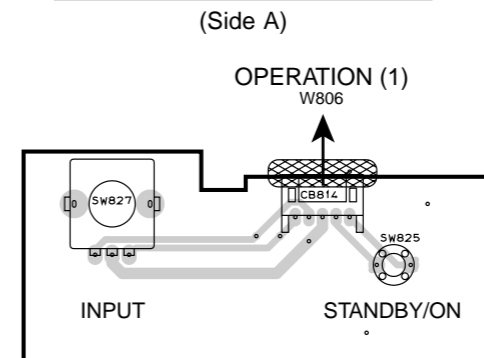

OPERATION (6) P.C.B. (Side A)

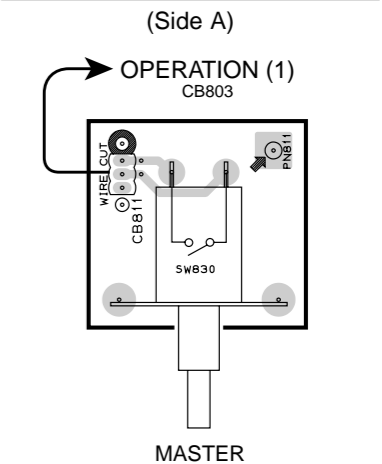

PRINTED CIRCUIT BOARD

OPERATION (7) P.C.B.

(Side A)

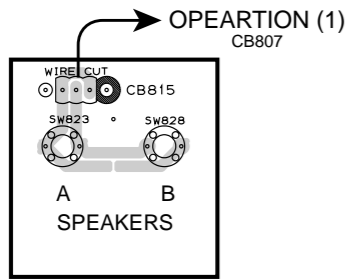

OPERATION (8) P.C.B.

(Side A)

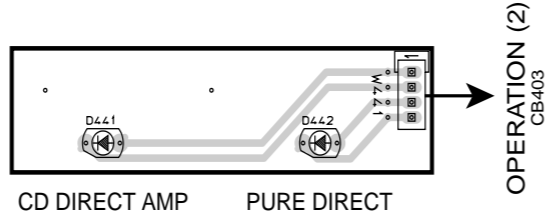

OPERATION (9) P.C.B.

(Side A)

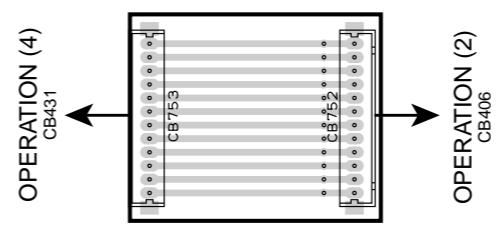

OPERATION (10) P.C.B.

(Side A)

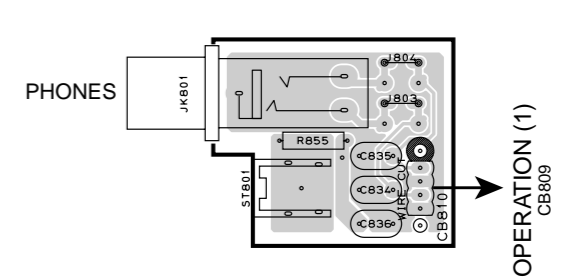

OPERATION (7) P.C.B.

(Side B) Lead Free Solder Used

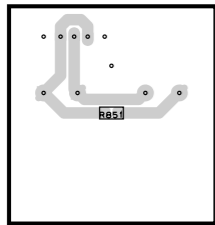

OPERATION (11) P.C.B.

(Side A)

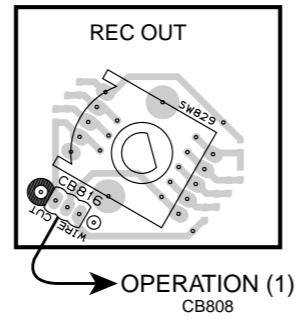

OPERATION (13) P.C.B.

(Side A)

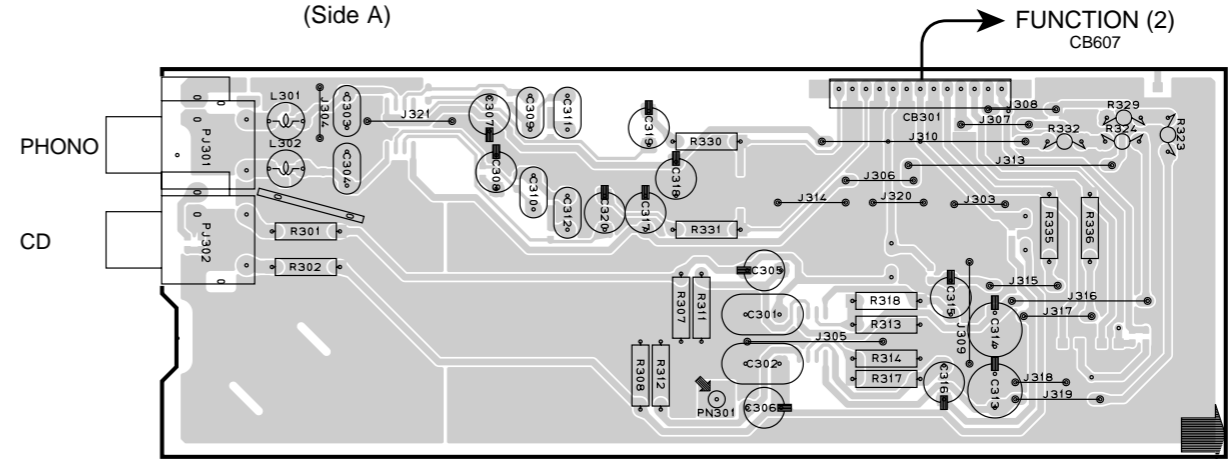

OPERATION (11) P.C.B.

(Side B) Lead Free Solder Used

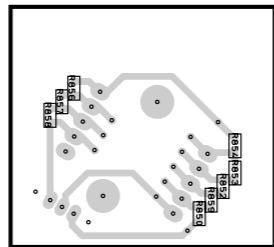

OPERATION (13) P.C.B.

(Side B) Lead Free Solder Used

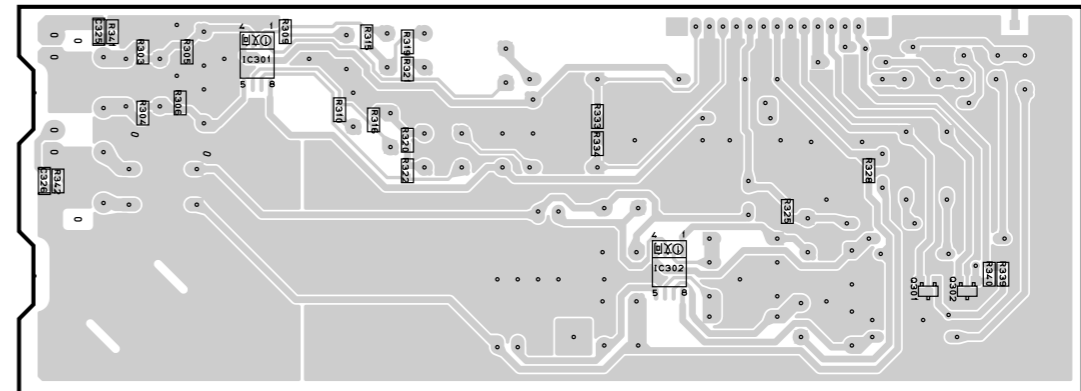

PRINTED CIRCUIT BOARD Lead Free Solder Used

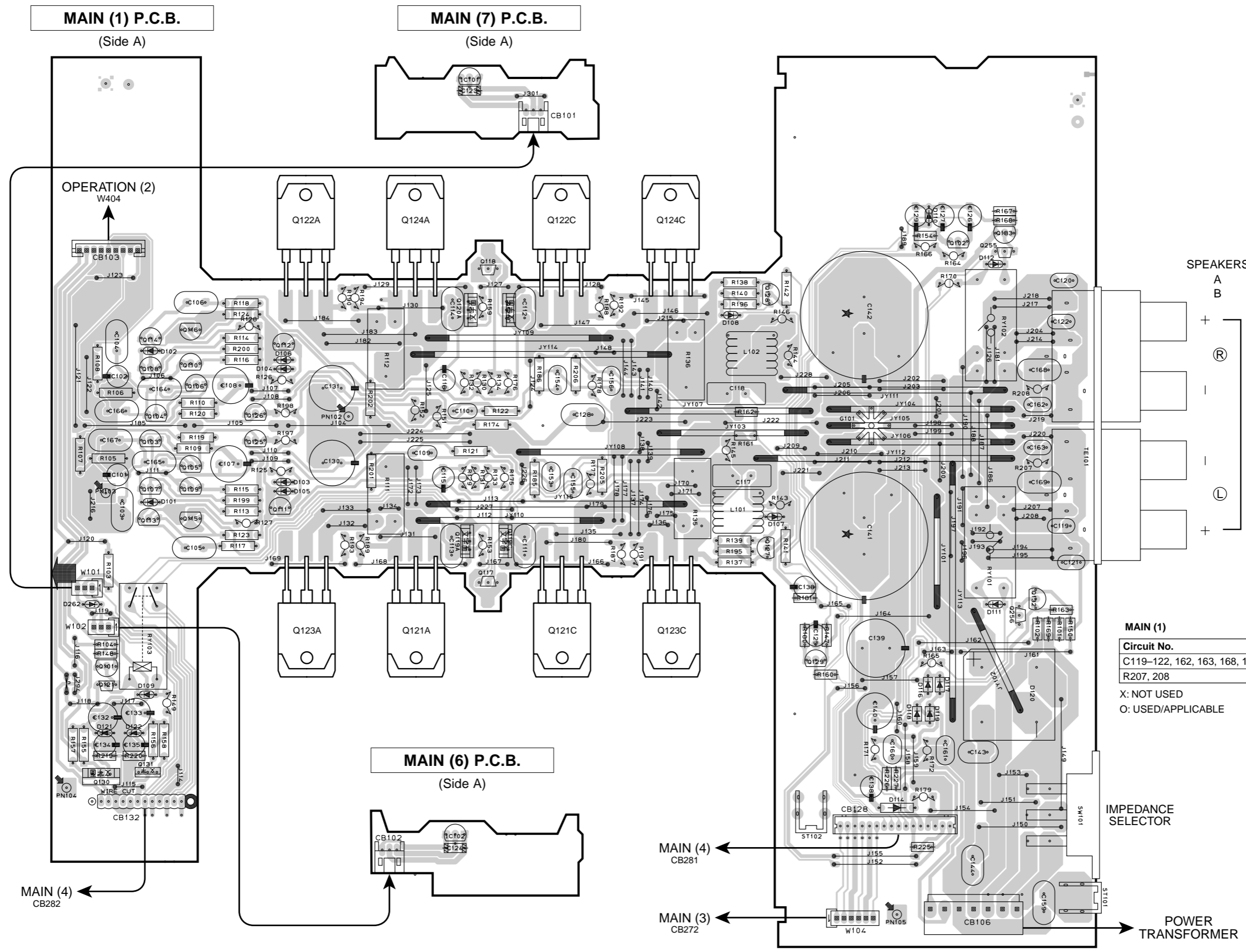

MAIN (1)

Circuit No.	R, A, G, E, L	U, C
C119-122, 162, 163, 168, 169	O	X
R207, 208	O	X

X: NOT USED
O: USED/APPLICABLE

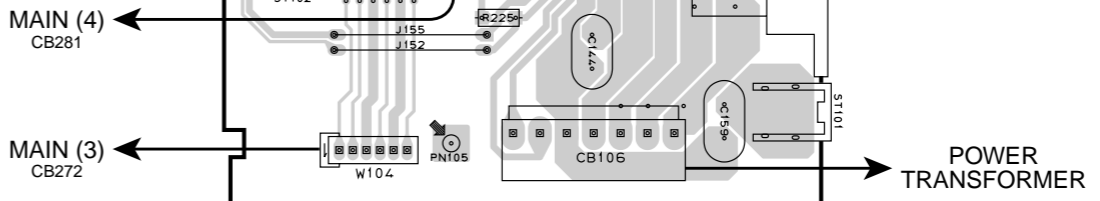
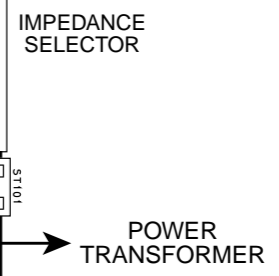

1
2
3
4
5
6

PRINTED CIRCUIT BOARD Lead Free Solder Used

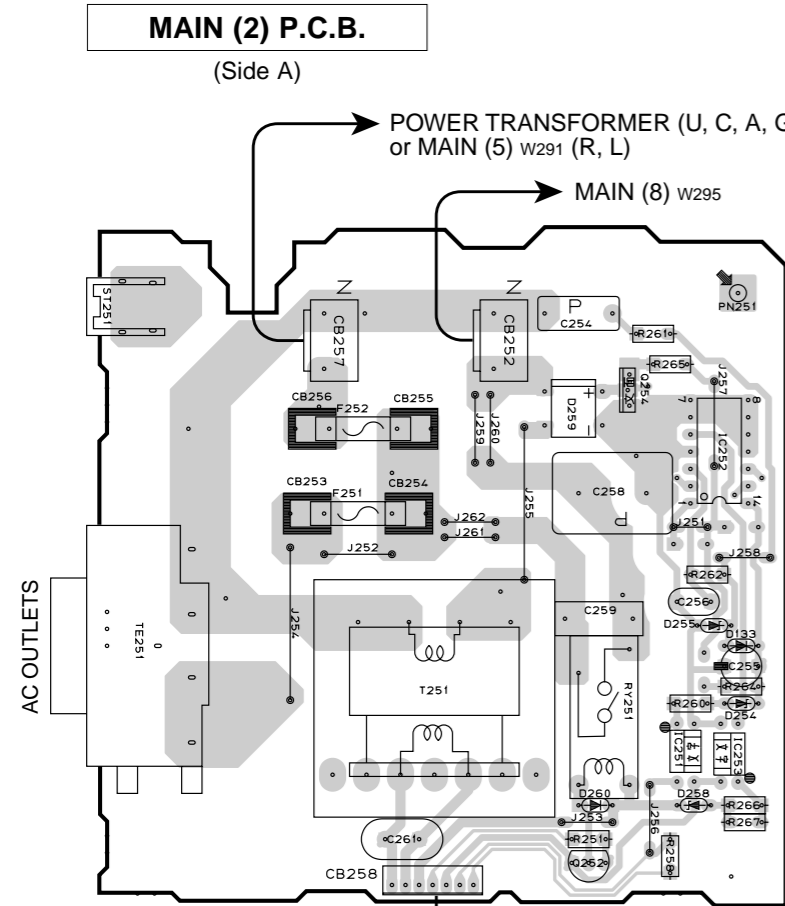

MAIN (2)

Circuit No.	U, C	R	A	G, E	L
J252	X	O	O	X	O
CB253, 254	O	X	X	O	X
F251	O	X	X	O	X

X: NOT USED
O: USED/APPLICABLE

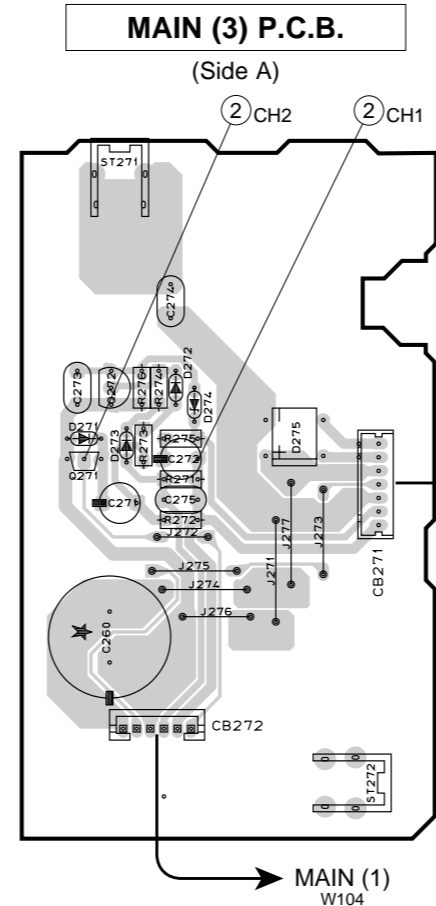

Point ②
CH 1 : (+) of C272
CH 2 : Collector of Q271

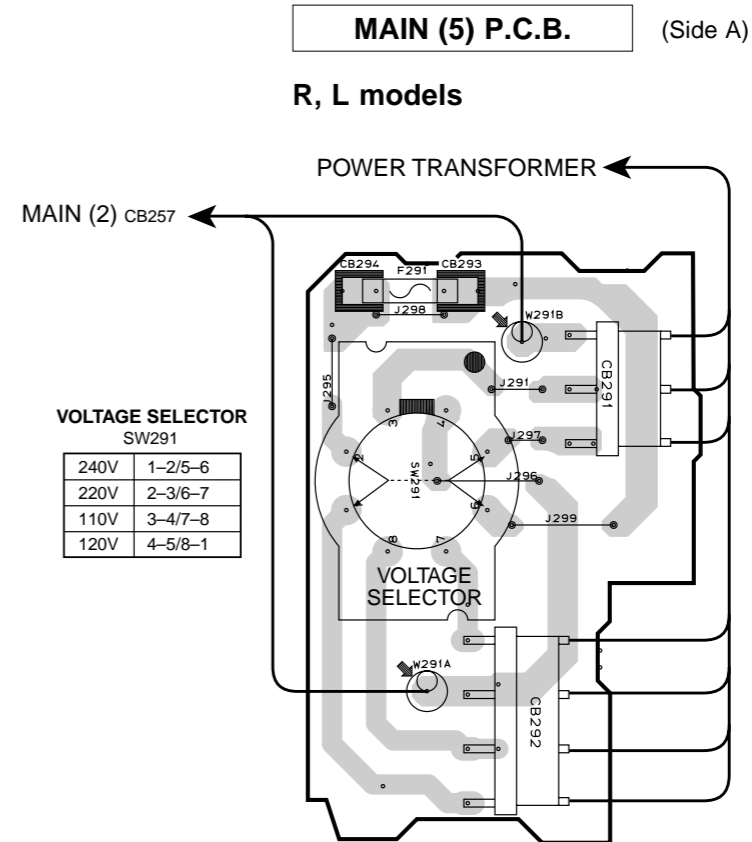
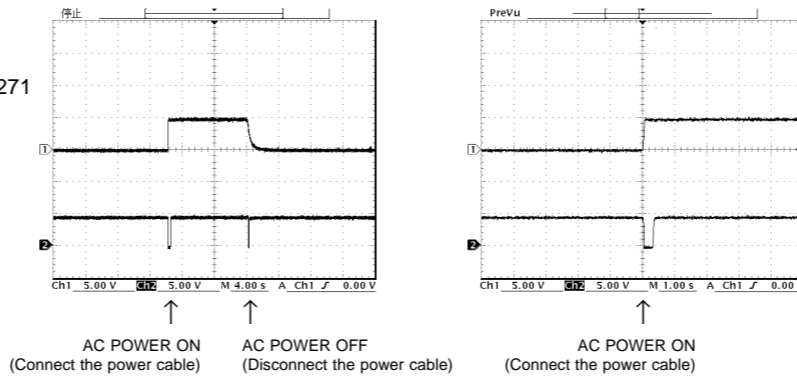

MAIN (5)

Circuit No.	R	L
CB293, 294	O	X
F291	O	X
J298	X	O

X: NOT USED
O: USED/APPLICABLE

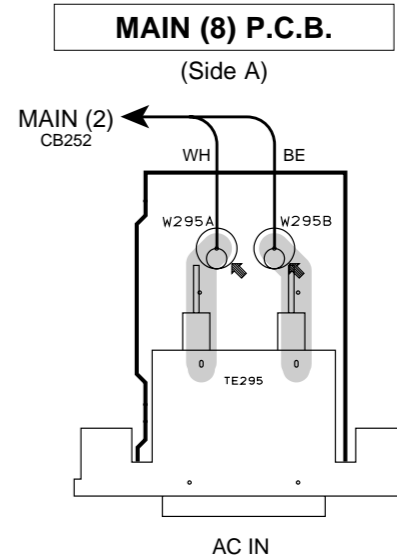
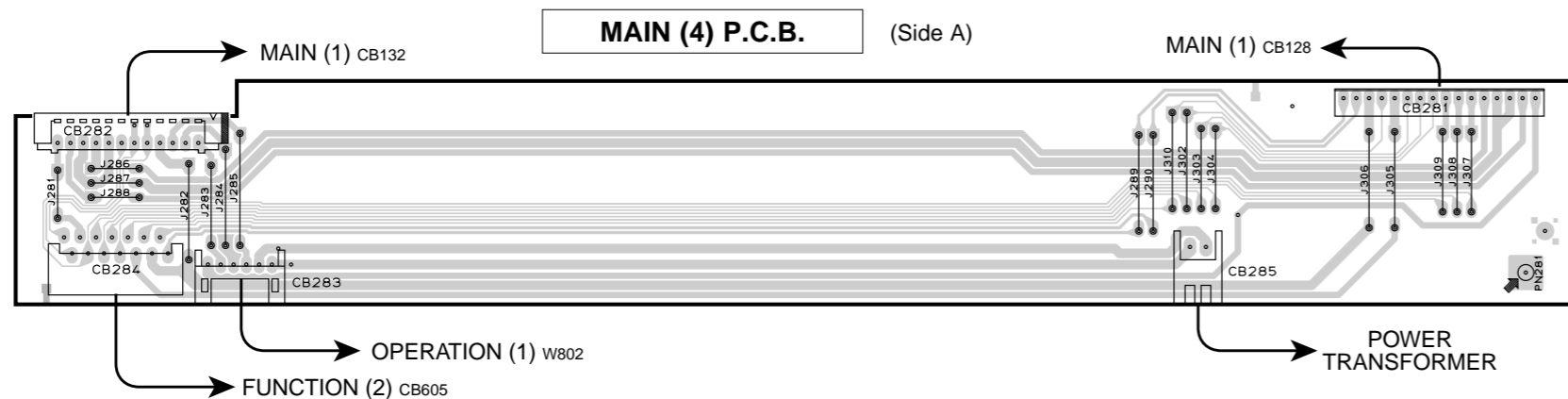

PIN CONNECTION DIAGRAM

ICs

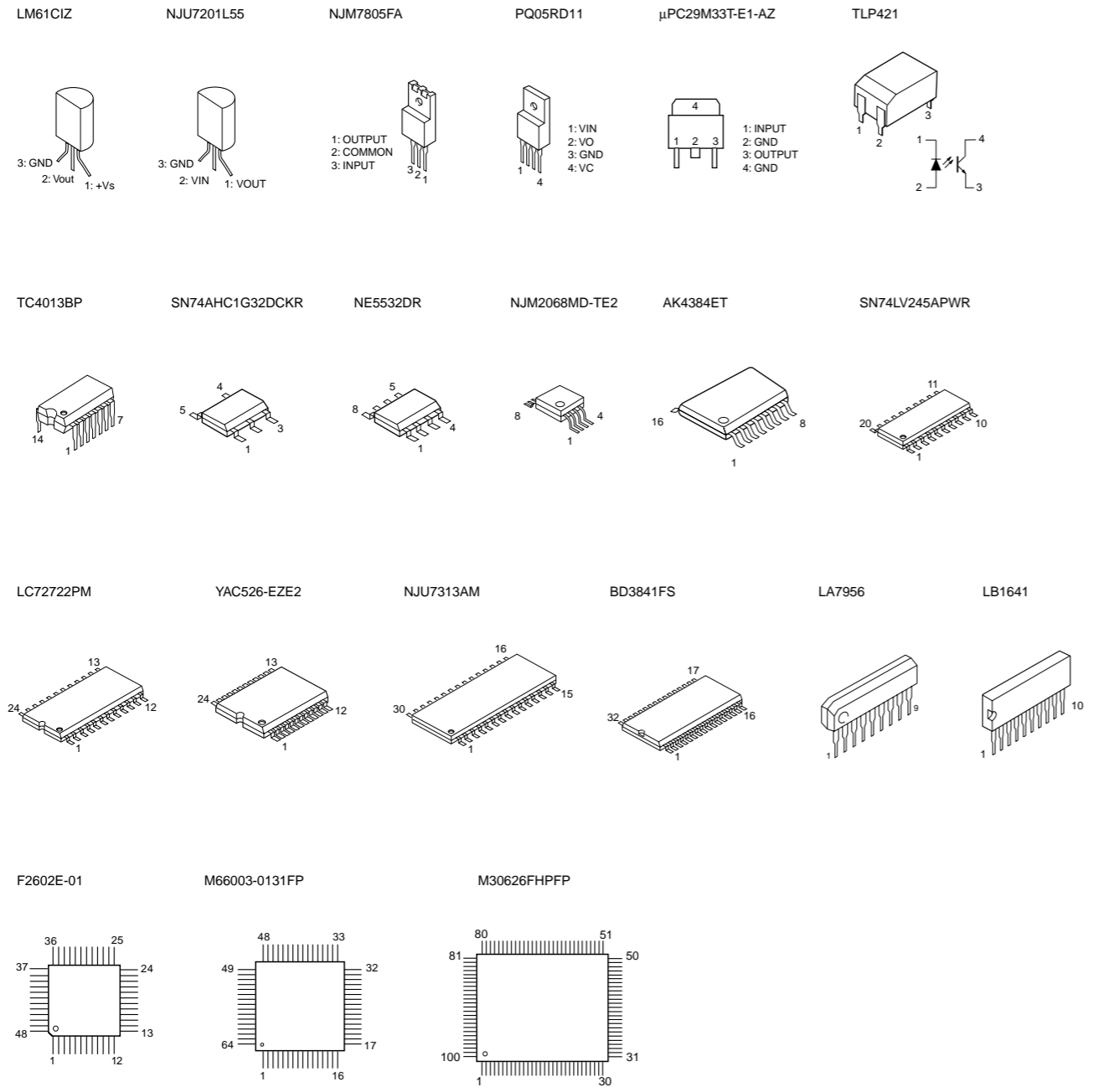

Diodes

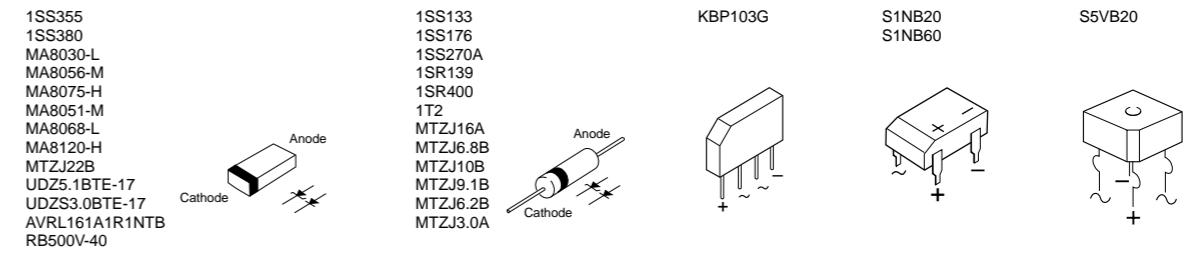

Transistors

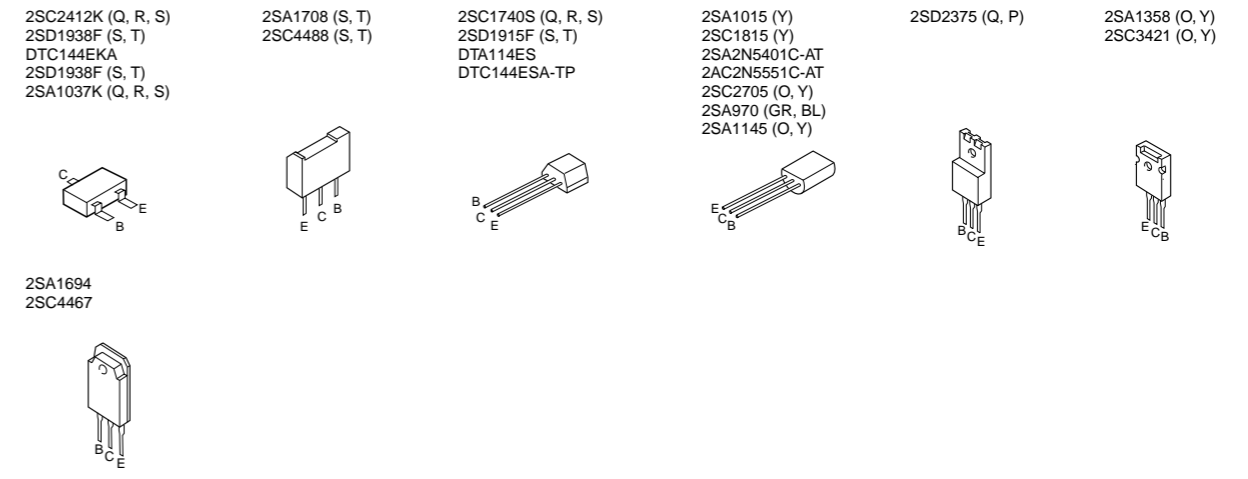

FETs

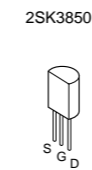

SCHEMATIC DIAGRAM (OPERATION)

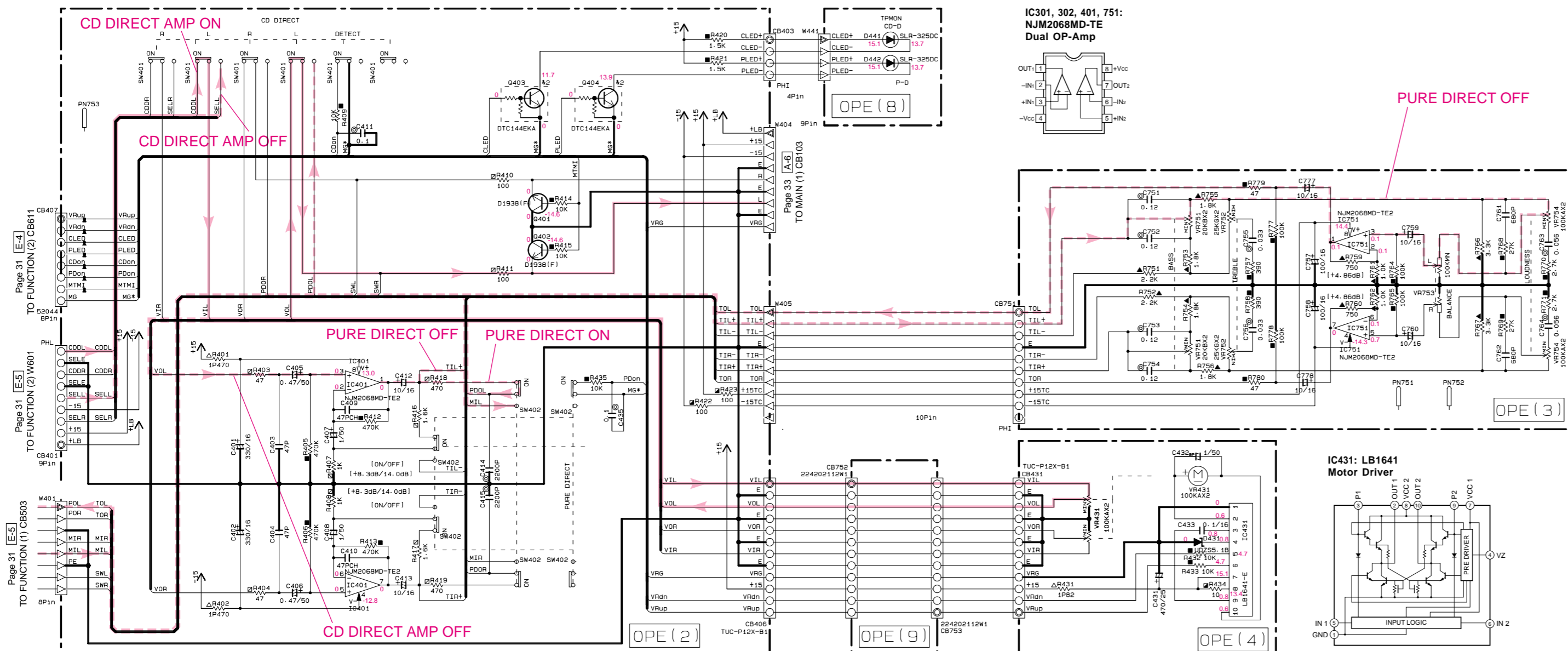

RESISTOR		CAPACITOR	
REMARKS	PARTS NAME	REMARKS	PARTS NAME
NO MARK	CARBON FILM RESISTOR (P=5)	NO MARK	ELECTROLYTIC CAPACITOR
△	METAL OXIDE FILM RESISTOR	⊗	TANTALUM CAPACITOR
□	METAL FILM RESISTOR	⊙	CERAMIC CAPACITOR
△	METAL PLATE RESISTOR	○	CERAMIC TUBULAR CAPACITOR
⊗	FIRE PROOF CARBON FILM RESISTOR	○	POLYSTYRENE FILM CAPACITOR
□	CEMENT MOLDED RESISTOR	⊙	MICA CAPACITOR
⊗	SEMI VARIABLE RESISTOR	⊙	POLYPROPYLENE FILM CAPACITOR
■	CHIP RESISTOR	⊙	SEMICONDUCTIVE CERAMIC CAPACITOR

NOTICE (model)

(J)..... JAPAN
 (U)..... U.S.A
 (C)..... CANADA
 (R)..... GENERAL
 (T)..... CHINA
 (K)..... KOREA
 (A)..... AUSTRALIA
 (S)..... BRITISH
 (G)..... STANDARD
 (L)..... SINGAPORE
 (E)..... SOUTH EUROPE
 (V)..... TAIWAN

Interchangeable Parts at Manufacture-Stage

Mark	Reference Parts Number	Parts Name
k1	G802	2SC2412K(0/R/S) 2SD0601AR(L/A) (0/R/S)
k2	G403-404	DTC144EKA KRC104S-RTK/B

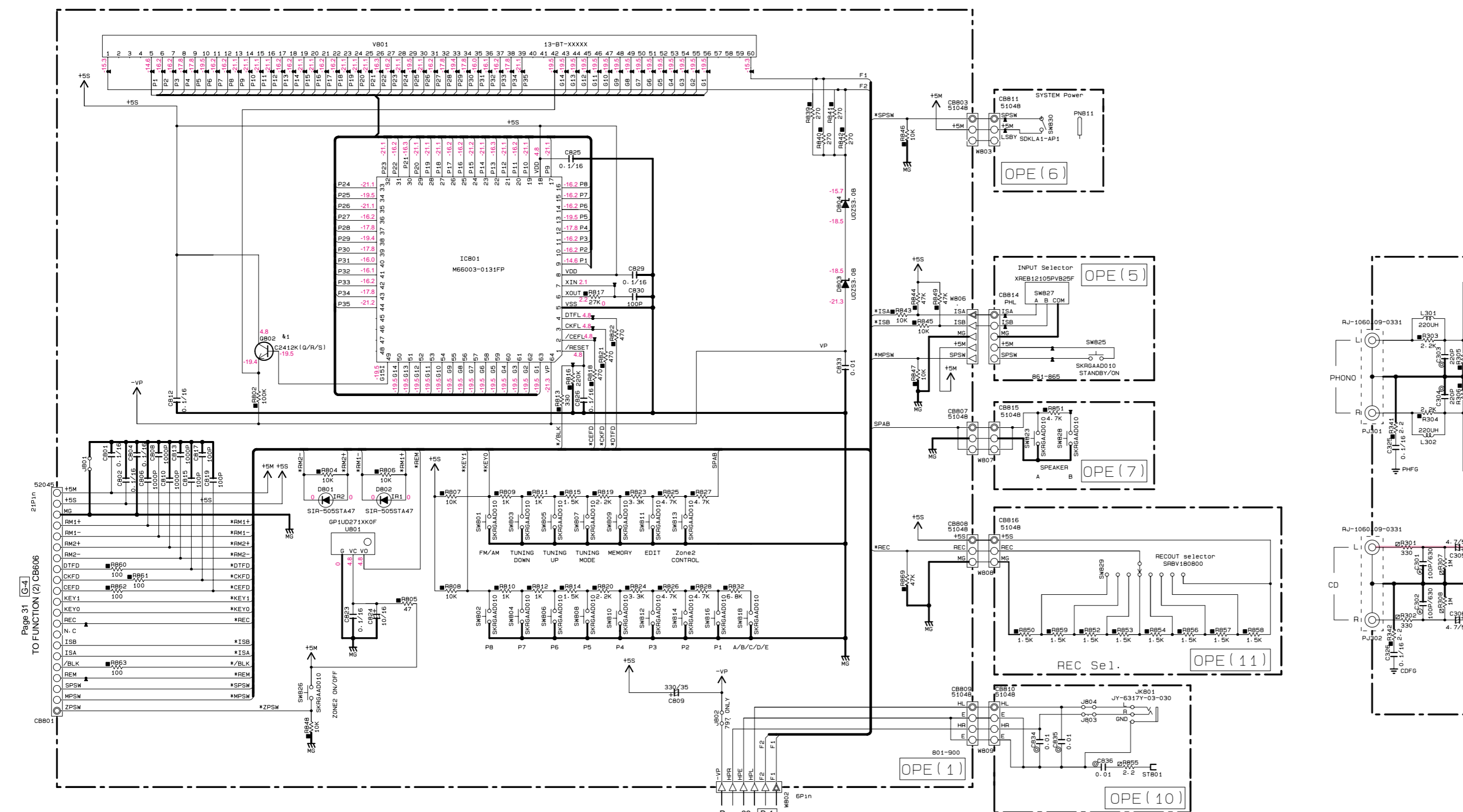

* All voltages are measured with a 10MΩ/V DC electronic volt meter.
 * Components having special characteristics are marked △ and must be replaced with parts having specifications equal to those originally installed.
 * Schematic diagram is subject to change without notice.

SCHEMATIC DIAGRAM (MAIN)

Page 32 [E-3] TO OPERATION (1) W802
Page 31 [E-4] TO FUNCTION (2) CB605
TO POWER TRANSFORMER

IC101, 102 : LM61C1Z
Temperature Sensor

CAPACITOR

REMARKS	PARTS NAME	UNIT
NO MARK	ELECTROLYTIC CAPACITOR	μF
⊗	TANTALUM CAPACITOR	μF
NO MARK	CERAMIC CAPACITOR	μF
⊙	CERAMIC TUBULAR CAPACITOR	μF
○	POLYESTER FILM CAPACITOR	μF
○	POLYSTYRENE FILM CAPACITOR	μF
○	MICA CAPACITOR	μF
○	POLYPROPYLENE FILM CAPACITOR	μF
○	SEMICONDUCTIVE CERAMIC CAPACITOR	μF

RESISTOR

REMARKS	PARTS NAME	UNIT
NO MARK	CARBON FILM RESISTOR (P=5)	Ω
⊗	CARBON FILM RESISTOR (P=10)	Ω
△	METAL OXIDE FILM RESISTOR	Ω
△	METAL FILM RESISTOR	Ω
△	METAL PLATE RESISTOR	Ω
□	FIRE PROOF CARBON FILM RESISTOR	Ω
□	CEMENT MOLDED RESISTOR	Ω
□	SEMI VARIABLE RESISTOR	Ω
■	CHIP RESISTOR	Ω

NOTICE (model)
(J)..... JAPAN
(U)..... U.S.A
(C)..... CANADA
(R)..... GENERAL
(T)..... CHINA
(K)..... KOREA
(A)..... AUSTRALIA
(B)..... BRITISH
(G)..... EUROPE
(L)..... SINGAPORE
(E)..... SOUTH EUROPE
(V)..... TAIWAN

Interchangeable Parts at Manufacture-Stage

Mark	Reference Parts Number	Parts Name
K1	D101-106-109-111-112-113-256-257-260-271-273	HSB104
K2	C254	0.047/400 0.047/630
K3		
K4	D254	29K3950 29K3491
K5	C258	0.047/400 0.047/630

Reference No	U-C	R	A	G-E	L
S1	C119-122-162-163	X	X	0.01 UM65410	0.01 UM65410
S2	R207-208	X	X	IP4.7 V939270	IP4.7 V939270
S3	C168-169	X	X	0.017/100 ME10290	0.017/100 ME10290
S4					
S5					
S6					
S7	TE251	VU54310	V586740	V191500	VU54340 VU54340
S8	J252	X	VN50000	VN50000	X VN50000
S9	CB253-254	WC05070	X	X	WC05070 X
S10	F251	Y8A125V	X	X	TE-5A7825V X
S11	C254	0.047/400 WB99710	0.022/630 WC24160	0.022/630 WC24160	0.022/630 WC24160
S12	C258	0.17/400 WB99760	0.033/630 WC24160	0.033/630 WC24160	0.033/630 WC24160
S13	F252	Y8A125V W641070	Y4L2820V K800279	Y4L2820V K800279	Y4L2820V K800279
S14	F251	Y8A125V XW62840	XW62840 XW62840	XW62840 XW62840	XW62840 XW62840
S15	C260	3300/25 LW04933	3300/25 LW04933	3300/25 LW04933	3300/25 LW04933
S16	SW291	X	X	X	ME40294 W07370
S17	CB253-254	X	WC05070	X	X X
S18	CB291	X	W33780	X	X W33780
S19	CB292	X	W33780	X	X W33780
S20	F291	X	K800279	X	X X
S21	W291	X	W476540	X	X W476540
S22	J295-296-297	X	VN50000	X	X VN50000
S23	TE101	WC63190	WC63190	W47750	W47750
S24	J298	X	X	X	X VN50000

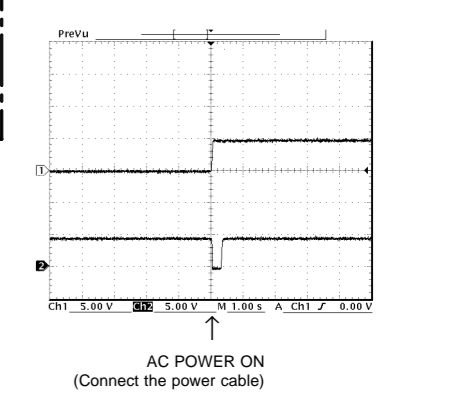
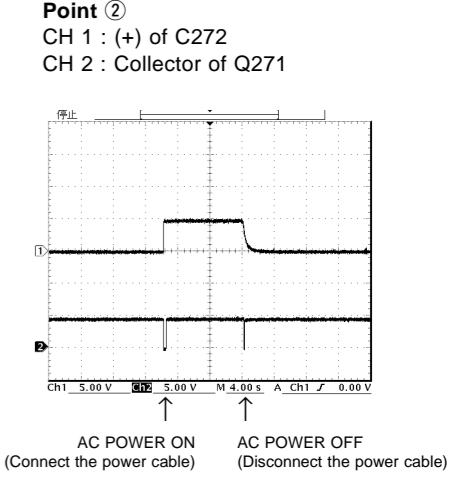
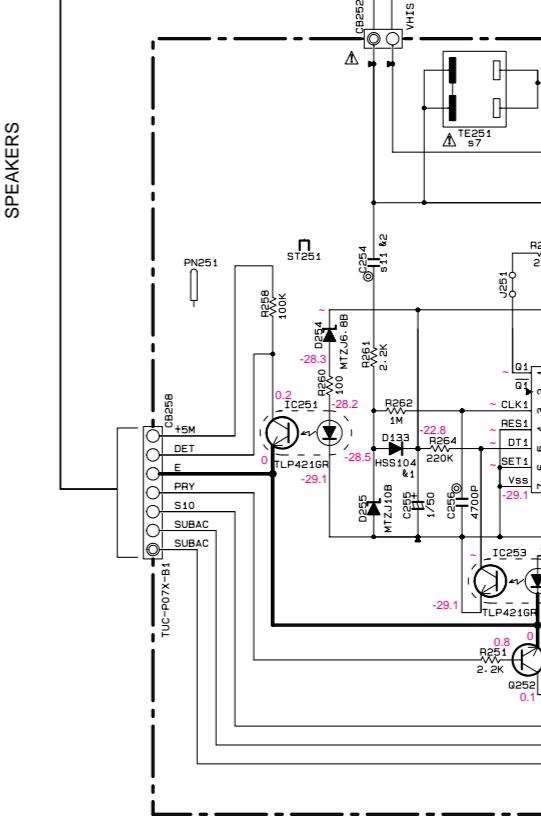
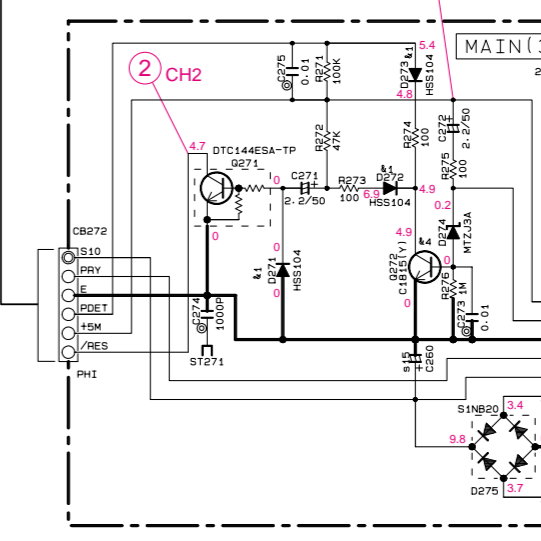
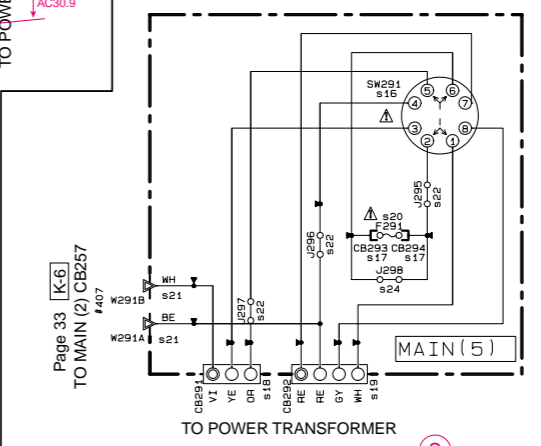
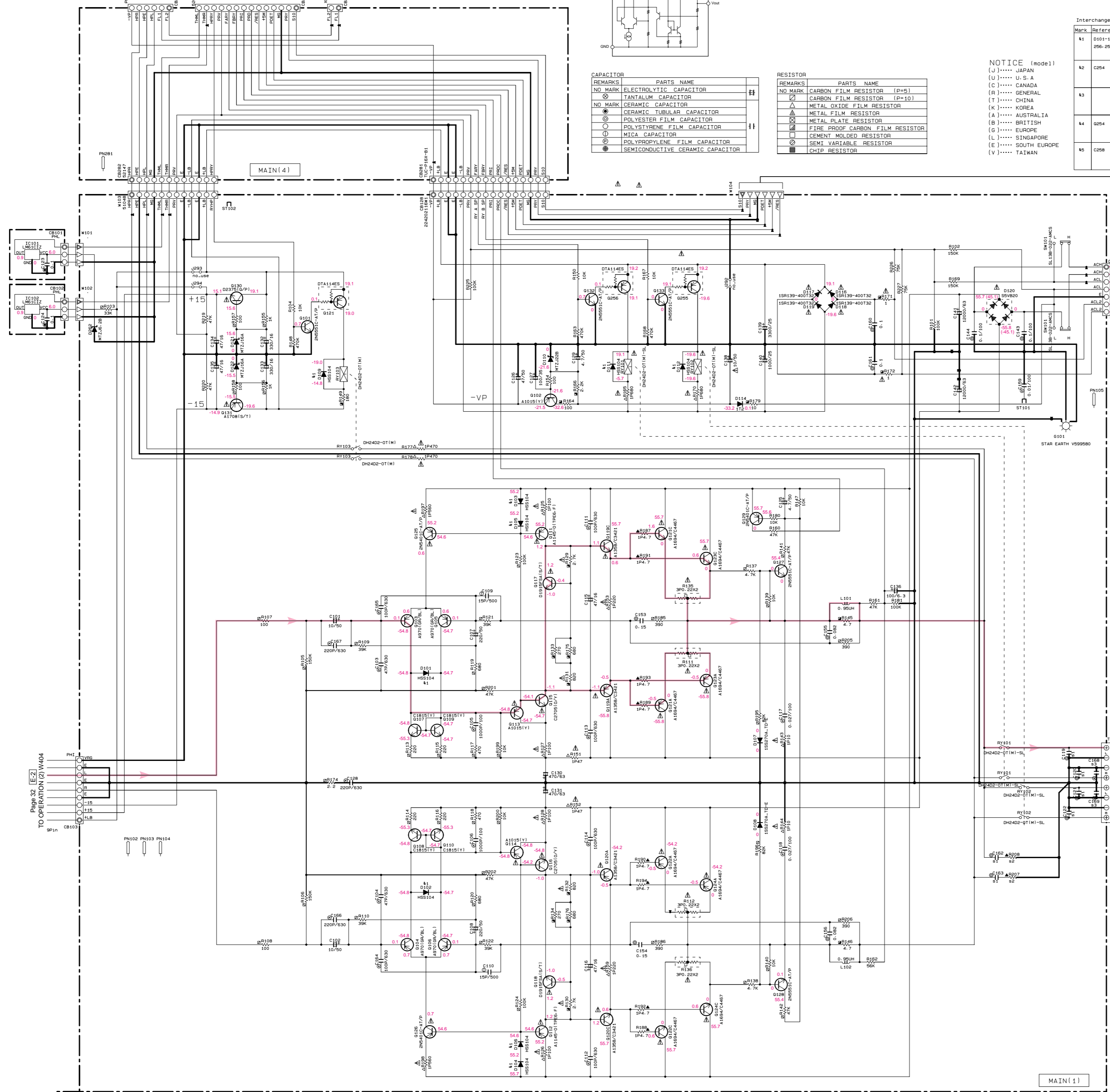

* All voltages are measured with a 10MΩ/V DC electronic volt meter.
* Components having special characteristics are marked △ and must be replaced with parts having specifications equal to those originally installed.
* Schematic diagram is subject to change without notice.

■ SCHEMATIC DIAGRAM (XM)

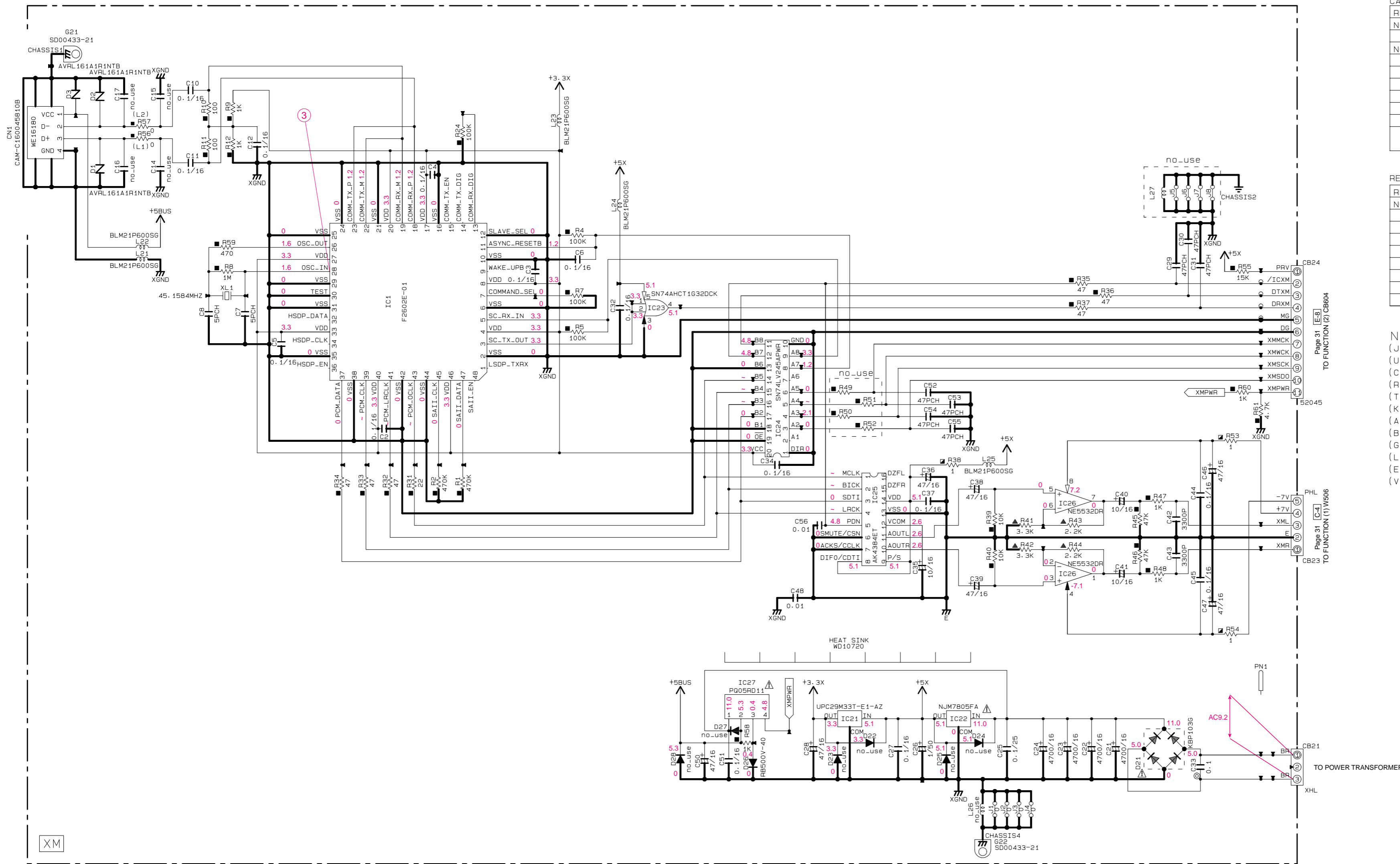

REMARKS	PARTS NAME	
NO MARK	ELECTROLYTIC CAPACITOR	#
⊗	TANTALUM CAPACITOR	
NO MARK	CERAMIC CAPACITOR	#
●	CERAMIC TUBULAR CAPACITOR	
⊙	POLYESTER FILM CAPACITOR	
○	POLYSTYRENE FILM CAPACITOR	
⊖	MICA CAPACITOR	
⊕	POLYPROPYLENE FILM CAPACITOR	
⊗	SEMICONDUCTIVE CERAMIC CAPACITOR	
⊙	POLYPHENYLENE SULFIDE FILM CAPACITOR	

REMARKS	PARTS NAME	
NO MARK	CARBON FILM RESISTOR (P=5)	
⊠	CARBON FILM RESISTOR (P=10)	
△	METAL OXIDE FILM RESISTOR	
⊠	METAL FILM RESISTOR	
⊠	METAL PLATE RESISTOR	
⊠	FIRE PROOF CARBON FILM RESISTOR	
⊠	CEMENT MOLDED RESISTOR	
⊠	SEMI VARIABLE RESISTOR	
⊠	CHIP RESISTOR	

NOTICE (model)

(J)..... JAPAN
 (U)..... U.S.A
 (C)..... CANADA
 (R)..... GENERAL
 (T)..... CHINA
 (K)..... KOREA
 (A)..... AUSTRALIA
 (B)..... BRITISH
 (G)..... EUROPE
 (L)..... SINGAPORE
 (E)..... SOUTH EUROPE
 (V)..... TAIWAN

XM

IC23 : SN74AHCT1G32DCKR
Single 2 Input OR

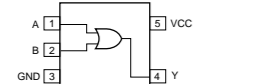

IC24 : SN74LV245APWR
Octal 3-State Bus Transceivers

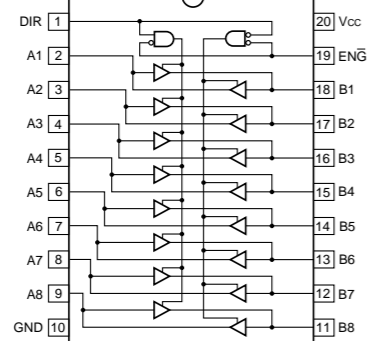

IC26 : NE5532DR
Dual OP-Amp

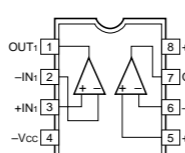

IC27 : PQ05RD11
Regulator

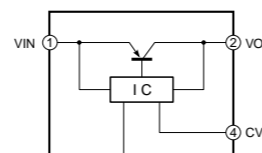

IC25 : AK4384ET
D/A Converter

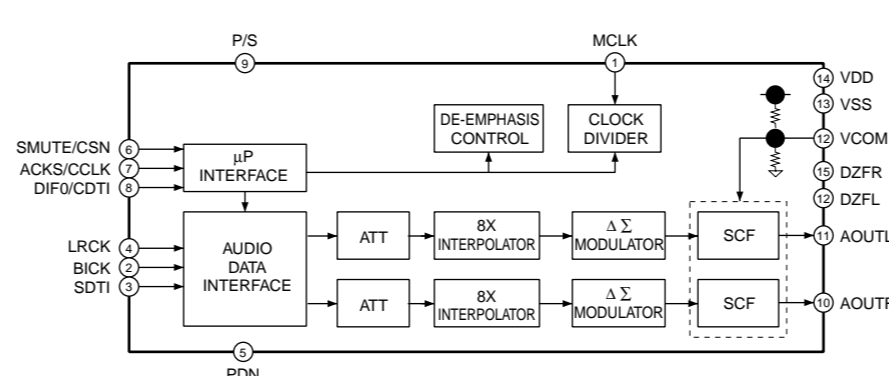

Point ③ (Pin 28 of IC1)

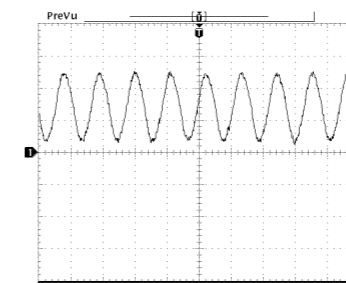

* All voltages are measured with a 10MΩ/V DC electronic volt meter.
 * Components having special characteristics are marked △ and must be replaced with parts having specifications equal to those originally installed.
 * Schematic diagram is subject to change without notice.

PARTS LIST

■ ELECTRICAL PARTS

■ WARNING

Components having special characteristics are marked \triangle and must be replaced with parts having specifications equal to those originally installed.

ABBREVIATIONS IN THIS LIST ARE AS FOLLOWS :

C.A.EL.CHP	: CHIP ALUMI. ELECTROLYTIC CAP	L.EMIT	: LIGHT EMITTING MODULE
C.CE	: CERAMIC CAP	LED.DSPLY	: LED DISPLAY
C.CE.ARRAY	: CERAMIC CAP ARRAY	LED.INFRD	: LED, INFRARED
C.CE.CHP	: CHIP CERAMIC CAP	MODUL.RF	: MODULATOR, RF
C.CE.ML	: MULTILAYER CERAMIC CAP	PHOT.CPL	: PHOTO COUPLER
C.CE.M.CHP	: CHIP MULTILAYER CERAMIC CAP	PHOT.INTR	: PHOTO INTERRUPTER
C.CE.SAFTY	: RECOGNIZED CERAMIC CAP	PHOT.RFLCT	: PHOTO REFLECTOR
C.CE.TUBLR	: CERAMIC TUBULAR CAP	PIN.TEST	: PIN, TEST POINT
C.CE.SMI	: SEMI CONDUCTIVE CERAMIC CAP	PLST.RIVET	: PLASTIC RIVET
C.EL	: ELECTROLYTIC CAP	R.ARRAY	: RESISTOR ARRAY
C.MICA	: MICA CAP	R.CAR	: CARBON RESISTOR
C.ML.FLM	: MULTILAYER FILM CAP	R.CAR.CHP	: CHIP RESISTOR
C.MP	: METALLIZED PAPER CAP	R.CAR.FP	: FLAME PROOF CARBON RESISTOR
C.MYLAR	: MYLAR FILM CAP	R.CEMENT	: CEMENT RESISTOR
C.MYLAR.ML	: MULTILAYER MYLAR FILM CAP	R.FUS	: FUSABLE RESISTOR
C.PAPER	: PAPER CAPACITOR	R.MTL.CHP	: CHIP METAL FILM RESISTOR
C.PLS	: POLYSTYRENE FILM CAP	R.MTL.FLM	: METAL FILM RESISTOR
C.POL	: POLYESTER FILM CAP	R.MTL.OXD	: METAL OXIDE FILM RESISTOR
C.POLY	: POLYETHYLENE FILM CAP	R.MTL.PLAT	: METAL PLATE RESISTOR
C.PP	: POLYPROPYLENE FILM CAP	RSNR.CE	: CERAMIC RESONATOR
C.TNTL	: TANTALUM CAP	RSNR.CRYS	: CRYSTAL RESONATOR
C.TNTL.CHP	: CHIP TANTALUM CAP	R.TW.CEM	: TWIN CEMENT FIXED RESISTOR
C.TRIM	: TRIMMER CAP	SCR.BND.HD	: BIND HEAD B-TITE SCREW
CN	: CONNECTOR	SCR.BW.HD	: BW HEAD TAPPING SCREW
CN.BS.PIN	: CONNECTOR, BASE PIN	SCR.CUP	: CUP TITE SCREW
CN.CANNON	: CONNECTOR, CANNON	SCR.TERM	: SCREW TERMINAL
CN.DIN	: CONNECTOR, DIN	SCR.TR	: SCREW, TRANSISTOR
CN.FLAT	: CONNECTOR, FLAT CABLE	SUPRT.PCB	: SUPPORT, P.C.B.
CN.POST	: CONNECTOR, BASE POST	SURG.PRTCT	: SURGE PROTECTOR
COIL.MX.AM	: COIL, AM MIX	SW.TACT	: TACT SWITCH
COIL.AT.FM	: COIL, FM ANTENNA	SW.LEAF	: LEAF SWITCH
COIL.DT.FM	: COIL, FM DETECT	SW.LEVER	: LEVER SWITCH
COIL.MX.FM	: COIL, FM MIX	SW.MICRO	: MICRO SWITCH
COIL.OUTPT	: OUTPUT COIL	SW.PUSH	: PUSH SWITCH
DIOD.ARRAY	: DIODE ARRAY	SW.RT.ENC	: ROTARY ENCODER
DIODE.BRG	: DIODE BRIDGE	SW.RT.MTR	: ROTARY SWITCH WITH MOTOR
DIODE.CHP	: CHIP DIODE	SW.RT	: ROTARY SWITCH
DIODE.SHOT	: SCHOTTKY BARRIER DIODE	SW.SLIDE	: SLIDE SWITCH
DIODE.VAR	: VARACTOR DIODE	TERM.SP	: SPEAKER TERMINAL
DIOD.Z.CHP	: CHIP ZENER DIODE	TERM.WRAP	: WRAPPING TERMINAL
DIODE.ZENR	: ZENER DIODE	THRMST.CHP	: CHIP THERMISTOR
DSCR.CE	: CERAMIC DISCRIMINATOR	TR.CHP	: CHIP TRANSISTOR
FER.BEAD	: FERRITE BEADS	TR.DGT	: DIGITAL TRANSISTOR
FER.CORE	: FERRITE CORE	TR.DGT.CHP	: CHIP DIGITAL TRANSISTOR
FET.CHP	: CHIP FET	TRANS	: TRANSFORMER
FL.DSPLY	: FLUORESCENT DISPLAY	TRANS.PULS	: PULSE TRANSFORMER
FLTR.CE	: CERAMIC FILTER	TRANS.PWR	: POWER TRANSFORMER ASS'y
FLTR.COMB	: COMB FILTER MODULE	TUNER.AM	: TUNER PACK, AM
FLTR.LC.RF	: LC FILTER, EMI	TUNER.FM	: TUNER PACK, FM
GND.MTL	: GROUND PLATE	TUNER.PK	: FRONT-END TUNER PACK
GND.TERM	: GROUND TERMINAL	VR	: ROTARY POTENTIOMETER
HOLDER.FUS	: FUSE HOLDER	VR.MTR	: POTENTIOMETER WITH MOTOR
IC.PRTCT	: IC PROTECTOR	VR.SW	: POTENTIOMETER WITH ROTARY SW
JUMPER.CN	: JUMPER CONNECTOR	VR.SLIDE	: SLIDE POTENTIOMETER
JUMPER.TST	: JUMPER, TEST POINT	VR.TRIM	: TRIMMER POTENTIOMETER
L.DTCT	: LIGHT DETECTING MODULE		

Note) Those parts marked with “#” are not included in the P.C.B. ass'y.

P.C.B. FUNCTION

Ref No.	Part No.	Description	Market
*	WG053300	P.C.B.	FUNCTION UC
*	WG053400	P.C.B.	FUNCTION RL
*	WG053500	P.C.B.	FUNCTION A
*	WG053600	P.C.B.	FUNCTION GE
CB351	V7828400	SOCKET	17P SE TUC SERIES
CB451	V7827500	SOCKET	8P SE TUC SERIES
CB501	V7828400	SOCKET	17P SE TUC SERIES
CB502	V7827900	SOCKET	12P TE TUC SERIES
CB503	VB858700	CN. BS. PIN	8P
CB504	V7828400	SOCKET	17P SE TUC SERIES
CB551-552	V7826700	CN	17P TE TUC SERIES
CB602	V7826200	CN	12P TE TUC SERIES
CB603	V7826700	CN	17P TE TUC SERIES
CB604	VM859500	CN. BS. PIN	11P UC
CB605	VN394900	CN. BS. PIN	14P
CB606	VQ047600	CN. BS. PIN	21P
CB607	V7826300	CN	13P TE TUC SERIES
CB608	VM859600	CN. BS. PIN	15P
CB609	V7825800	CN	8P TE TUC SERIES
CB610	VQ044400	CN. BS. PIN	9P
CB611	VP682200	CN. BS. PIN	8P
C351-355	US062220	C. CE. CHP	220pF 50V B
C356-357	US064100	C. CE. CHP	0.01uF 50V B
C358-359	US063100	C. CE. CHP	1000pF 50V B
C360-361	UU337100	C. EL	10uF 16V
C362-363	US063100	C. CE. CHP	1000pF 50V B
* C364-365	UU318330	C. EL	330uF 6.3V
C366-367	UU337100	C. EL	10uF 16V
C368-369	US062470	C. CE. CHP	470pF 50V B
C370-371	UU338100	C. EL	100uF 16V
C372-373	US064100	C. CE. CHP	0.01uF 50V B
C451-453	UR837100	C. EL	10uF 16V
C454-456	UR819100	C. EL	1000uF 6.3V
C457-462	US135100	C. CE. CHP	0.1uF 16V
C463-465	UR837470	C. EL	47uF 16V
C466	US061470	C. CE. CHP	47pF 50V B
C467	UR837100	C. EL	10uF 16V
C468	UR838330	C. EL	330uF 16V
C469	US135100	C. CE. CHP	0.1uF 16V
C501-506	US062220	C. CE. CHP	220pF 50V B
C507-508	US062100	C. CE. CHP	100pF 50V B
C509-510	US062220	C. CE. CHP	220pF 50V B
C511-512	US062100	C. CE. CHP	100pF 50V B
C513-516	UU337100	C. EL	10uF 16V
C517-518	US064100	C. CE. CHP	0.01uF 50V B
C519-530	UU337100	C. EL	10uF 16V
C531-532	UU338330	C. EL	330uF 16V
C533-536	UU337100	C. EL	10uF 16V
C537	US064100	C. CE. CHP	0.01uF 50V B
C538-539	US062100	C. CE. CHP	100pF 50V B
C540-541	UU337100	C. EL	10uF 16V
C542-545	US135100	C. CE. CHP	0.1uF 16V
C546-547	UU337100	C. EL	10uF 16V

* New Parts

Ref No.	Part No.	Description	Market
C548	US135100	C. CE. CHP	0.1uF 16V
C549	UU337100	C. EL	10uF 16V
C550-551	UR867470	C. EL	47uF 50V
C552-553	UR837100	C. EL	10uF 16V
C554-555	UR837470	C. EL	47uF 16V
C556-557	UR867470	C. EL	47uF 50V
C558-559	US064100	C. CE. CHP	0.01uF 50V B
C560-561	UU338100	C. EL	100uF 16V
C562-563	UR838100	C. EL	100uF 16V
C564-567	UU337100	C. EL	10uF 16V
C568	UA655680	C. MYLAR	0.68uF 50V J
C569	UU337100	C. EL	10uF 16V
C570-571	UA654390	C. MYLAR	0.039uF 50V J
C572	UU337100	C. EL	10uF 16V
C573-574	US064100	C. CE. CHP	0.01uF 50V B
C575-576	UU337470	C. EL	47uF 16V
C577	UA655680	C. MYLAR	0.68uF 50V J
C578-579	UR837100	C. EL	10uF 16V
C601	UR877100	C. EL	10uF 63V
C602-603	US135100	C. CE. CHP	0.1uF 16V
C604-607	UR866220	C. EL	2.2uF 50V
C608	UR837100	C. EL	10uF 16V
C609-610	US135100	C. CE. CHP	0.1uF 16V
C611	UR818220	C. EL	220uF 6.3V
C612	WB165500	C. EL	0.33F 5.5V
C613	UR818220	C. EL	220uF 6.3V
C614	UR818100	C. EL	100uF 6.3V
C615	UR837470	C. EL	47uF 16V
C616	US135100	C. CE. CHP	0.1uF 16V
C617	UR837470	C. EL	47uF 16V
C618	UR837100	C. EL	10uF 16V
C619	US135100	C. CE. CHP	0.1uF 16V
C620	UR838330	C. EL	330uF 16V
C621	US135100	C. CE. CHP	0.1uF 16V
C622-623	US062330	C. CE. CHP	330pF 50V B
C624	US064100	C. CE. CHP	0.01uF 50V B
C625	US063100	C. CE. CHP	1000pF 50V B
C626	US062100	C. CE. CHP	100pF 50V B
C627-628	UR837470	C. EL	47uF 16V
C629	US062560	C. CE. CHP	560pF 50V B
C630	US061270	C. CE. CHP	27pF 50V B
C631	US135100	C. CE. CHP	0.1uF 16V
C632	US061270	C. CE. CHP	27pF 50V B
C633	UR837470	C. EL	47uF 16V
C634-636	US062100	C. CE. CHP	100pF 50V B
C637	UR866220	C. EL	2.2uF 50V
D351-354	VT332900	DIODE	1SS355
D355	VU990500	DIODE. ZENR	MA8030-L 2.9V
D451	VU996300	DIODE. ZENR	MA8120-H 12.3V
D501-502	VT332900	DIODE	1SS355
D503-504	VU994300	DIODE. ZENR	MA8075-H 7.7V
D505-506	VU993700	DIODE. ZENR	MA8068-L 6.6V
D601-602	VU992600	DIODE. ZENR	MA8051-M 5.1V

* New Parts

P.C.B. FUNCTION & OPERATION
--

Ref No.	Part No.	Description	Market	
D603-604	VT332900	DIODE	1SS355	
D605	VV833200	DIODE	1SS380	
D606	VU992600	DIODE.ZENR	MA8051-M 5.1V	
D607	VT332900	DIODE	1SS355	
D608	VU993000	DIODE.ZENR	MA8056-M 5.6V	
D609	VU996300	DIODE.ZENR	MA8120-H 12.3V	
IC351	X3505A00	IC	NJM2068MD-TE2	
IC451-453	XH436A00	IC	LA7956	
IC501	X5043A00	IC	NJU7313AM	
IC502	X3547A00	IC	BD3841FS	
* IC503	X5574A00	IC	YAC526-EZE2	
IC504-510	X3505A00	IC	NJM2068MD-TE2	
IC601	X5041A00	IC	NJU7201L55 5.5V	
* IC602	X7092A00	IC.CPU	MASK ROM	
IC603	X0082A00	IC	LC72722PM	GE
JK351-354	VJ726800	JACK.MNI	LGY6501-0600C	
PJ351	WD195200	JACK.PIN	4P	
* PJ352	WD195600	JACK.PIN	1P	
PJ451-453	WD195500	JACK.PIN	RJ-1078_04-0351A	
* PJ501	WD195400	JACK.PIN	6P	
PJ502-503	WD195200	JACK.PIN	4P	
PN451	V9637500	PIN	L=70 #18	UC
PN501	V9637500	PIN	L=70 #18	
PN601	V9637500	PIN	L=70 #18	
Q351	VZ725900	TR	2SD1938F S,T	
Q352	VP872600	TR	2SA1708 S,T	
Q353	VV655700	TR.DGT	DTC144EKA	
Q354-356	VZ725900	TR	2SD1938F S,T	
Q451	VS826900	TR	2SD2375 Q,P	
Q501-504	VZ725900	TR	2SD1938F S,T	
Q505	iC181510	TR	2SC1815 Y	
Q506	iA101510	TR	2SA1015 Y	
Q507	VP872700	TR	2SC4488 S,T	
Q508	VP872600	TR	2SA1708 S,T	
Q601-604	VV556500	TR	2SA1037K Q,R,S	
Q605	VP872600	TR	2SA1708 S,T	
Q606	VV655700	TR.DGT	DTC144EKA	
Q607	iC181510	TR	2SC1815 Y	
Q608	VS826900	TR	2SD2375 Q,P	
Q609	iC174020	TR	2SC1740S QRS	GE
Q610	VV556500	TR	2SA1037K Q,R,S	
R380-381	HV755100	R.CAR.FP	100 1/4W	
R460-462	HV753220	R.CAR.FP	2.2 1/4W	
R465	VY893200	R.MTL.OXD	12 1W	
R525-526	HV755100	R.CAR.FP	100 1/4W	
R569-570	VP940400	R.MTL.OXD	100 1W	
R571-572	HV755100	R.CAR.FP	100 1/4W	
R588-589	HV755100	R.CAR.FP	100 1/4W	
R601		R.CHP	15K 1/16W J	RLAGE
R613		R.CHP	0 1/16W J	UC
R613		R.CHP	820 1/16W J	RL
R613		R.CHP	1.5K 1/16W J	A
R613		R.CHP	2.7K 1/16W J	GE

* New Parts

Ref No.	Part No.	Description	Market	
R665	VY893200	R.MTL.OXD	12 1W	
R677		R.CHP	100K 1/16W J	GE
R678		R.CHP	33K 1/16W J	GE
R679		R.CHP	100 1/16W J	UC
R681		R.CHP	100 1/16W J	UC
R683		R.CHP	100 1/16W J	UC
R684		R.CHP	3.3K 1/16W J	GE
R686		R.CHP	100 1/16W J	UC
R687		R.CHP	1.5K 1/16W J	UC
R688		R.CHP	22K 1/16W J	GE
R689		R.CHP	1.5K 1/16W J	UC
R698		R.CHP	100 1/16W J	GE
R710-711		R.CHP	470 1/16W J	GE
R714		R.CHP	10K 1/16W J	GE
R715	HV753220	R.CAR.FP	2.2 1/4W	
R717		R.CHP	10K 1/16W J	GE
ST351	V4040500	SCR.TERM	M3	
ST601	V4040500	SCR.TERM	M3	
XL601	WA674700	RSNR.CE	16MHz CSTLS16MOX51	
XL602	V3930900	RSNR.CRYS	4.332MHz	GE
*	WG054500	P.C.B.	OPERATION	
CB301	V7828000	SOCKET	13P SE TUC SERIES	
CB401	VB858800	CN.BS.PIN	9P	
CB403	VB390000	CN.BS.PIN	4P	
CB406	V7827900	SOCKET	12P TE TUC SERIES	
CB407	VP682300	CN.BS.PIN	8P	
CB431	V7827900	SOCKET	12P TE TUC SERIES	
CB751	VB390600	CN.BS.PIN	10P	
CB752-753	V7826200	CN	12P TE TUC SERIES	
CB801	VQ047600	CN.BS.PIN	21P	
CB814	VB858400	CN.BS.PIN	5P	
C301-302	WE100500	C.PP	100pF 630V	
C303-304	UA652220	C.MYLAR	220pF 50V J	
C305-306	UU366470	C.EL	4.7uF 50V	
C307-308	UU318220	C.EL	220uF 6.3V	
C309-310	UA654330	C.MYLAR	0.033uF 50V J	
C311-312	UA653910	C.MYLAR	9100pF 50V J	
C313-314	UU338330	C.EL	330uF 16V	
C315-318	UU338100	C.EL	100uF 16V	
C319-320	UU337100	C.EL	10uF 16V	
C325-326	US135100	C.CE.CHP	0.1uF 16V	
C401-402	UU338330	C.EL	330uF 16V	
C403-404	FG651470	C.CE	47pF 50V	
C405-406	UU365470	C.EL	0.47uF 50V	
* C407-408	UU366100	C.EL	1uF 50V	
C409-410	US061470	C.CE.CHP	47pF 50V B	
C411	UA655100	C.MYLAR	0.1uF 50V J	
C412-413	UU337100	C.EL	10uF 16V	
C414-415	UA653220	C.MYLAR	2200pF 50V J	
C431	UR848470	C.EL	470uF 25V	

* New Parts

P.C.B. OPERATION & MAIN

Ref No.	Part No.	Description	Market
C432	UN866100	C.EL 1uF 50V	
C433	US135100	C.CE.CHP 0.1uF 16V	
C435	UA655100	C.MYLAR 0.1uF 50V J	
C751-754	UA655120	C.MYLAR 0.12uF 50V J	
C755-756	UA654330	C.MYLAR 0.033uF 50V J	
C757-758	UU338100	C.EL 100uF 16V	
C759-760	UU337100	C.EL 10uF 16V	
C761-762	US062680	C.CE.CHP 680pF 50V B	
C763-764	UA654560	C.MYLAR 0.056uF 50V J	
C777-778	UU337100	C.EL 10uF 16V	
C801-802	US135100	C.CE.CHP 0.1uF 16V	
C804	US135100	C.CE.CHP 0.1uF 16V	
C806	US063100	C.CE.CHP 1000pF 50V B	
C808	US063100	C.CE.CHP 1000pF 50V B	
* C809	UR858330	C.EL 330uF 35V	
C810	US063100	C.CE.CHP 1000pF 50V B	
C812	US135100	C.CE.CHP 0.1uF 16V	
C813	US063100	C.CE.CHP 1000pF 50V B	
C815	US062100	C.CE.CHP 100pF 50V B	
C817	US062100	C.CE.CHP 100pF 50V B	
C819	US062100	C.CE.CHP 100pF 50V B	
C823	US135100	C.CE.CHP 0.1uF 16V	
C824	UM397100	C.EL 10uF 16V	
C825-826	US135100	C.CE.CHP 0.1uF 16V	
C829	US135100	C.CE.CHP 0.1uF 16V	
C830	US062100	C.CE.CHP 100pF 50V B	
C833	US064100	C.CE.CHP 0.01uF 50V B	
C834-836	UA654100	C.MYLAR 0.01uF 50V J	
D431	VU171900	DIODE.ZENR UDZ5.1B 5.1V	
D441-442	VR711500	LED(or) SLR-325DC	
D801-802	V2598200	LED SIR-505ST	
* D803-804	VU171300	DIODE.ZENR UDZS3.0BTE-17 3.0V	
IC301-302	X3505A00	IC NJM2068MD-TE2	
IC401	X3505A00	IC NJM2068MD-TE2	
IC431	XF494A00	IC LB1641	
IC751	X3505A00	IC NJM2068MD-TE2	
IC801	X6386A00	IC M66003-0131FP	
JK801	V4478300	JACK.PHONE JY-6317Y-03-030	
* PJ301-302	WD195100	JACK.PIN 2P	
PN301	V9637500	PIN L=70 #18	
PN751-753	V9637500	PIN L=70 #18	
PN811	V9637500	PIN L=70 #18	
Q301-302	VZ725900	TR 2SD1938F S,T	
Q401-402	VZ725900	TR 2SD1938F S,T	
Q403-404	VV655700	TR.DGT DTC144EKA	
Q802	VV556400	TR 2SC2412K Q,R,S	
R323-324	VP940400	R.MTL.OXD 100 1W	
R329	VP940800	R.MTL.OXD 470 1W	
R332	VP940800	R.MTL.OXD 470 1W	
R401-402	VP940800	R.MTL.OXD 470 1W	
R422-423	HV755100	R.CAR.FP 100 1/4W	
R431	VS267200	R.MTL.OXD 82 1W	
R434	HV754100	R.CAR.FP 10 1/4W	

* New Parts

Ref No.	Part No.	Description	Market
ST801	V4040500	SCR.TERM M3	
SW401-402	VV399800	SW.PUSH SPUN12	
SW801-814	WD483100	SW.TACT SKRGAAD010	
SW816	WD483100	SW.TACT SKRGAAD010	
SW818	WD483100	SW.TACT SKRGAAD010	
SW823	WD483100	SW.TACT SKRGAAD010	
SW825-826	WD483100	SW.TACT SKRGAAD010	
SW827	V9266400	SW.RT.ENC XREB12105PVB25F	
SW828	WD483100	SW.TACT SKRGAAD010	
* SW829	WF581600	SW.RT SRBV180800	
SW830	V4466400	SW.PUSH SDKLA1-AP1 TV-5	
U801	V8210200	L.DTCT GP1UD271XK	
* V801	WF519900	FL.DSPLY	
VR431	VR710500	VR.MTR A100K	
VR751	VP741800	VR B20K	
VR752	VP741900	VR G25K	
VR753	VP742000	VR MN100K	
VR754	WF774500	VR A100K	
* WG083700		SHEET	
VR380100		SPACER FL-T6	
* WG051700	P.C.B.	MAIN	UC
* WG051800	P.C.B.	MAIN	R
* WG051900	P.C.B.	MAIN	A
* WG052000	P.C.B.	MAIN	GE
* WG052100	P.C.B.	MAIN	L
CB101-102	VB858200	CN.BS.PIN 3P	
CB103	VB390500	CN.BS.PIN 9P	
CB106	LB932070	CN.BS.PIN 7P	
CB128	V7826600	CN 16P TE TUC SERIES	
CB252	VG879900	CN.BS.PIN 2P	
CB253-254	WC050700	CLIP.FUSE EYF-52BCY	UCGE
CB255-256	WC050700	CLIP.FUSE EYF-52BCY	
CB257	VG879900	CN.BS.PIN 2P	
CB258	V7827400	SOCKET 7P TE TUC SERIES	
CB271	V7825700	CN 7P TE TUC SERIES	
CB272	VB390200	CN.BS.PIN 6P	
CB281	V7828300	SOCKET 16P TE TUC SERIES	
CB282	VK025600	CN.BS.PIN 12P	
CB283	VB858500	CN.BS.PIN 6P	
CB284	VF982200	CN.BS.PIN 14P	
CB285	LB919020	CN.BS.PIN 2P	
* CB291	V9377800	CN.BS.PIN 3P SE VH SERIES	RL
* CB292	V9377900	CN.BS.PIN 4P SE VH SERIES	RL
CB293-294	WC050700	CLIP.FUSE EYF-52BCY	R
C101-102	UU367100	C.EL 10uF 50V	
C103-104	WE100400	C.PP 47pF 630V	
C105-106	WE101700	C.PP 1000pF 100V	
C107-108	UU368220	C.EL 220uF 50V	
C109-110	FU451150	C.MICA 15pF 500V	
C111-114	WE100500	C.PP 100pF 630V	

* New Parts

P.C.B. MAIN

Ref No.	Part No.	Description	Market
C115-116	UU337470	C.EL 47uF 16V	
* C117-118	UT954270	C.PP 0.027uF 100V J	
C119-122	UA654100	C.MYLAR 0.01uF 50V J	AGEL
C123-124	VJ599100	C.CE.TUBLR 0.1uF 50V	
C125	UU366470	C.EL 4.7uF 50V	
C126	UR067470	C.EL 47uF 50V	
C127	UR058100	C.EL 100uF 35V	
C128	WE100900	C.PP 220pF 630V	
C129	UR066470	C.EL 4.7uF 50V	
C130-131	UU378470	C.EL 470uF 63V	
C132-133	UU338330	C.EL 330uF 16V	
C134-135	UU337470	C.EL 47uF 16V	
* C136	UU318100	C.EL 100uF 6.3V	
△ C138	UR867100	C.EL 10uF 50V	
C139	UR749330	C.EL 3300uF 25V	
C140	UR849100	C.EL 1000uF 25V	
* C141-142	WG399500	C.EL 12000uF 63V	
C143-144	VR324900	C.MYLAR 0.1uF 100V	
C153-154	VK398900	C.MYLAR 0.15uF 50V	
C155-156	UA654820	C.MYLAR 0.082uF 50V J	
C159	WE102900	C.PP 0.01uF 100V	
C160-161	UA655100	C.MYLAR 0.1uF 50V J	
C162-163	UA654100	C.MYLAR 0.01uF 50V J	AGEL
C164-165	WE100500	C.PP 100pF 630V	
C166-167	WE100900	C.PP 220pF 630V	
C168-169	WE102900	C.PP 0.01uF 100V	AGEL
C254	WB687100	C.POL.MTL 0.047uF 400V	UC
C254	WC041600	C.PP 0.022uF 630V	RAGEL
C255	UR866100	C.EL 1uF 50V	
C256	UA653470	C.MYLAR 4700pF 50V J	
C258	WB696300	C.POL.MTL 0.1uF 400V	UC
* C258	WD257600	C.PP 0.047uF 800V	RAGEL
△ C259	V6185300	C.CE.SAFETY 0.01uF 275V	
C260	UR049330	C.EL 3300uF 25V	UCAGEL
C260	UR069330	C.EL 3300uF 50V	R
C261	WB121400	C.CE.SAFETY 0.01uF 295V	UC
C261	WE102900	C.PP 0.01uF 100V	RAGEL
C271-272	UR866220	C.EL 2.2uF 50V	
C273	UA654100	C.MYLAR 0.01uF 50V J	
C274	UA653100	C.MYLAR 1000pF 50V J	
C275	UA654100	C.MYLAR 0.01uF 50V J	
D101-106	VD631600	DIODE 1SS133,176	
D107-108	VN008700	DIODE 1SS270A	
D109	VD631600	DIODE 1SS133,176	
D110	VG442100	DIODE.ZENR MTZJ22B 22V	
D111-112	VD631600	DIODE 1SS133,176	
D114	VS997800	DIODE 1T2	
△ D116-119	VU264100	DIODE 1SR139,400	
△ D120	VM702000	DIODE.BRG S5VB20 3.5A 200V	
D121-122	VG441000	DIODE.ZENR MTZJ16A 16V	
D133	VD631600	DIODE 1SS133,176	
D254	VG438300	DIODE.ZENR MTZJ6.8B 6.8V	
D255	VG439500	DIODE.ZENR MTZJ10B 10V	
D258	VG439200	DIODE.ZENR MTZJ9.1B 9.1V	
△ D259	V4756800	DIODE S1NB60 1.0A 600V	
D260	VD631600	DIODE 1SS133,176	
D262	VG438000	DIODE.ZENR MTZJ6.2B 6.2V	
D271-273	VD631600	DIODE 1SS133,176	
D274	VG435800	DIODE.ZENR MTZJ3.0A 3.0V	
D275	VR253700	DIODE.BRG S1NB20 1A 200V	
△ F251	VT942900	FUSE T2.5A 250V	GE
△ F251	WG410700	FUSE 8A 125V	UC
△ F252	KB000790	FUSE T4A 250V	AGEL
△ F252	WG410700	FUSE 8A 125V	UCR
△ F291	KB000790	FUSE T4A 250V	R
G101	V5995800	PLATE.GND	
IC101-102	X0515A00	IC LM61CIZ THERMAL	
IC251	V8100500	PHOT.CPL TLP421 GR	
△ IC252	iG001180	IC TC4013BP FF	
IC253	V8100500	PHOT.CPL TLP421 GR	
PM102-105	V9637500	PIN L=70 #18	
PN251	V9637500	PIN L=70 #18	
PN281	V9637500	PIN L=70 #18	
Q101	WC398400	TR 2N5551C-AT	
Q102	iA101510	TR 2SA1015 Y	
Q103-106	iA097030	TR 2SA970 GR,BL	
Q107-110	iC181510	TR 2SC1815 Y	
△ Q111-112	VE198700	TR 2SA1145 0,Y	
△ Q113-114	iA101510	TR 2SA1015 Y	
△ Q115-116	VE198800	TR 2SC2705 0,Y	
△ Q117-118	VK432900	TR 2SD1915F S,T	
△ Q119A	iX603580	TR 2SA1358 0,Y	
△ Q119C	iX608520	TR 2SC3421 0,Y	
△ Q120A	iX603580	TR 2SA1358 0,Y	
△ Q120C	iX608520	TR 2SC3421 0,Y	
Q121	VD678500	TR.DGT DTA114ES	
△ Q125-126	WC397700	TR 2SA2N5401C-AT	
Q127-128	WC398400	TR 2SC2N5551C-AT	
Q129	WC397700	TR 2SA2N5401C-AT	
△ Q130	VS826900	TR 2SD2375 Q,P	
△ Q131	VP872600	TR 2SA1708 S,T	
Q132-133	WC398400	TR 2SC2N5551C-AT	
Q252	iC181510	TR 2SC1815 Y	
△ Q254	WC741200	FET 2SK3850	
Q255-256	VD678500	TR.DGT DTA114ES	
Q271	VV912300	TR.DGT DTC144ESA-TP	
Q272	iC181510	TR 2SC1815 Y	
△ R111-112	V3873200	R.CEMENT 0.22 3W	
△ R125-128	VP940400	R.MTL.OXD 100 1W	
△ R129-130	HV756270	R.CAR.FP 2.7K 1/4W	
△ R131-132	HV755820	R.CAR.FP 820 1/4W	
R133-134	HV755270	R.CAR.FP 270 1/4W	
△ R135-136	V3873200	R.CEMENT 0.22 3W	
△ R143-144	VP939800	R.MTL.OXD 10 1W	
R145-146	HV753470	R.CAR.FP 4.7 1/4W	
R149	HV755180	R.CAR.FP 180 1/4W	

* New Parts

* New Parts

P.C.B. MAIN & XM

Ref No.	Part No.	Description	Market
△	R151-152	VP940200 R.MTL.OXD 47 1W	
	R153	VP940600 R.MTL.OXD 220 1W	
	R159	VP940600 R.MTL.OXD 220 1W	
	R164	HV755100 R.CAR.FP 100 1/4W	
△	R165	VP941000 R.MTL.OXD 680 1W	
	R166	HV756220 R.CAR.FP 2.2K 1/4W	
△	R170	VP941000 R.MTL.OXD 680 1W	
△	R171-172	HV753100 R.CAR.FP 1 1/4W	
	R175-176	HV755680 R.CAR.FP 680 1/4W	
△	R177-178	VP940800 R.MTL.OXD 470 1W	
	R179	HV754100 R.CAR.FP 10 1/4W	
	R187-194	VP939700 R.MTL.FLM 4.7 1W	
△	R197-198	VP940900 R.MTL.OXD 560 1W	
	R207-208	VP939700 R.MTL.FLM 4.7 1W	AGEL
△	RY101-102	V6322600 RELAY DC DH24D2-OT(M)-SL	
	RY103	VK438300 RELAY DH24D2-OT/M2	
△	RY251	WE513800 RELAY DC HRM3H-DC12V	
	ST101-102	V4040500 SCR.TERM M3	
	ST251	V4040500 SCR.TERM M3	
	ST271-272	V4040500 SCR.TERM M3	
	SW101	V4104200 SW.SLIDE SL13B-022-AMCS	
△*	SW291	WB493700 VOLT.SELECT R8140246	R
△	SW291	WD073700 VOLT.SELECT R8140254	L
△	T251	X6351A00 TRANS.PWR	R
△*	T251	XW606A00 TRANS.PWR	UC
△*	T251	XW608A00 TRANS.PWR	AGEL
	TE101	WC631900 TERM.SP 8P LTS0810-1017FM	UCRA
*	TE101	WD477500 TERM.SP 8P LTS0810-1015FM	GEL
△	TE251	V5867400 OUTLET.AC 2P AC-182-GB-11V	R
△	TE251	VT915000 OUTLET.AC 1P	A
△	TE251	VU543100 OUTLET.AC 2P	UC
△	TE251	VU543400 OUTLET.AC 2P	GEL
	TE295	WB782600 AC INLET R-30190(26)	

* New Parts

Ref No.	Part No.	Description	Market
*	WG055200	P.C.B.	XM UC
	CB21	LB919030 CN.BS.PIN 3P	
	CB23	VB858400 CN.BS.PIN 5P	
	CB24	VM859500 CN.BS.PIN 11P	
	C2-6	US035100 C.CE.CHP 0.1uF 16V B	
	C7-8	US060500 C.CE.CHP 5pF 50V B	
	C10-12	US035100 C.CE.CHP 0.1uF 16V B	
	C21-24	UR739470 C.EL 4700uF 16V	
	C25	US145100 C.CE.CHP 0.1uF 25V	
	C26	UR866100 C.EL 1uF 50V	
	C27	US035100 C.CE.CHP 0.1uF 16V B	
	C28	UR837470 C.EL 47uF 16V	
	C29-31	US061470 C.CE.CHP 47pF 50V B	
	C32	US035100 C.CE.CHP 0.1uF 16V B	
	C33	VE326000 C.MYLAR 0.1uF 50V	
	C34	US035100 C.CE.CHP 0.1uF 16V B	
	C35	UR837100 C.EL 10uF 16V	
	C36	UR837470 C.EL 47uF 16V	
	C37	US135100 C.CE.CHP 0.1uF 16V	
	C38-39	UR837470 C.EL 47uF 16V	
	C40-41	UR837100 C.EL 10uF 16V	
	C42-43	US063330 C.CE.CHP 3300pF 50V B	
	C44-45	US135100 C.CE.CHP 0.1uF 16V	
	C46-47	UR837470 C.EL 47uF 16V	
	C48	US064100 C.CE.CHP 0.01uF 50V B	
	C50	UR837470 C.EL 47uF 16V	
	C51	US035100 C.CE.CHP 0.1uF 16V B	
	C52-55	US061470 C.CE.CHP 47pF 50V B	
	C56	US064100 C.CE.CHP 0.01uF 50V B	
*	CN1	WE161800 CN CAM-C16 4P SE	
	D1-3	WE674800 DIODE AVRL161A1R1NTB	
△	D21	WA653100 DIODE.BRG KBP103G 1.0A 200V	
	D26	V2376600 DIODE.SHOT RB500V-40	
	G21-22	WB438000 TERM.GND M4 SD00433-21	
*	IC1	X6227B00 IC F2602E-01	
	IC21	X6051A00 IC UPC29M33T-E1-AZ	
△	IC22	XJ607A00 IC NJM7805FA 5V	
	IC23	X2080A00 IC SN74AHCT1G32DCKR	
	IC24	X3693A00 IC SN74LV245APWR TRAN	
*	IC25	X6231A00 IC AK4384ET	
	IC26	X5482A00 IC NE5532DR OP AMP	
△	IC27	XU814A00 IC PQ05RD11 +5V 1.0A	
	PN1	V9637500 PIN L=70 #18	
	R38	HV753100 R.CAR.FP 1 1/4W	
	R53-54	HV753100 R.CAR.FP 1 1/4W	
*	XL1	WE436500 RSNR.CRY 45.1584M DSX840GA	
		WE774200 SCR.BND.HD 3x10 MFZN2W3	

* New Parts

CHIP RESISTORS

Ref No.	Part No.	Description	Market
	R.CHP	0	1/16W J
	R.CHP	2.2	1/16W J
	R.CHP	22	1/16W J
	R.CHP	27	1/16W J
	R.CHP	47	1/16W J
	R.CHP	75	1/16W J
	R.CHP	82	1/16W J
	R.CHP	100	1/16W J
	R.CHP	220	1/16W J
	R.CHP	270	1/16W J
	R.CHP	330	1/16W J
	R.CHP	390	1/16W J
	R.CHP	470	1/16W J
	R.CHP	820	1/16W J
	R.CHP	1K	1/16W J
	R.CHP	1.5K	1/16W J
	R.CHP	2.2K	1/16W J
	R.CHP	2.7K	1/16W J
	R.CHP	3.3K	1/16W J
	R.CHP	4.7K	1/16W J
	R.CHP	6.8K	1/16W J
	R.CHP	10K	1/16W J
	R.CHP	15K	1/16W J
	R.CHP	22K	1/16W J
	R.CHP	27K	1/16W J
	R.CHP	33K	1/16W J
	R.CHP	39K	1/16W J
	R.CHP	47K	1/16W J
	R.CHP	100K	1/16W J
	R.CHP	220K	1/16W J
	R.CHP	470K	1/16W J
	R.CHP	1M	1/16W J
	R.MTL.CHP	82	1/16W D
	R.MTL.CHP	180	1/16W D
	R.MTL.CHP	560	1/16W D
*	R.MTL.CHP	750	1/16W D
	R.MTL.CHP	1.0K	1/16W D
	R.MTL.CHP	1.5K	1/16W D
	R.MTL.CHP	1.8K	1/16W D
	R.MTL.CHP	2.2K	1/16W D
	R.MTL.CHP	2.7K	1/16W D
	R.MTL.CHP	3.3K	1/16W D
	R.MTL.CHP	3.9K	1/16W D
	R.MTL.CHP	8.2K	1/16W D
	R.MTL.CHP	12K	1/16W D
	R.MTL.CHP	20K	1/16W D
	R.MTL.CHP	33K	1/16W D
*	R.MTL.CHP	100K	1/16W D

NOTE

- The chip resistor is not supplied as a replacement part.
- When a chip resistor is necessary, use the following part.
AAX60720: CHIP RESISTOR SAMPLE BOOK

Parts List for Carbon Resistors

Value	1/4W Type Part No.	1/6W Type Part No.	Value	1/4W Type Part No.	1/6W Type Part No.
1.0 Ω	HJ35 3100	HF85 3100	10 kΩ	HF45 7100	HF45 7100
1.8 Ω	HJ35 3180	*	11 kΩ	HF45 7110	HF45 7110
2.2 Ω	HJ35 3220	HF85 3220	12 kΩ	HJ35 7120	HF85 7120
3.3 Ω	HJ35 3330	HF85 3330	13 kΩ	HF45 7130	HF45 7130
4.7 Ω	HJ35 3470	HF85 3470	15 kΩ	HF45 7150	HF45 7150
5.6 Ω	HJ35 3560	HF85 3560	18 kΩ	HF45 7180	HF45 7180
10 Ω	HF45 4100	HF45 4100	22 kΩ	HF45 7220	HF45 7220
15 Ω	HJ35 4150	HF85 4150	24 kΩ	HF45 7240	HF45 7240
22 Ω	HF45 4220	HF45 4220	27 kΩ	HJ35 7270	HF85 7270
27 Ω	HJ35 4270	HF85 4270	30 kΩ	HF45 7300	HF45 7300
33 Ω	HF45 4330	HF45 4330	33 kΩ	HF45 7330	HF45 7330
39 Ω	HJ35 4470	HF85 4390	36 kΩ	HF45 7360	HF45 7360
47 Ω	HF45 4470	HF45 4470	39 kΩ	HF45 7390	HF45 7390
56 Ω	HF45 4560	HF45 4560	47 kΩ	HF45 7470	HF45 7470
68 Ω	HF45 4680	HF45 4680	51 kΩ	HF45 7510	HF45 7510
75 Ω	HF45 4750	HF45 4750	56 kΩ	HF45 7560	HF45 7560
82 Ω	HF45 4820	HF45 4820	62 kΩ	HF45 7620	HF45 7620
91 Ω	HF45 4910	HF45 4910	68 kΩ	HF45 7680	HF45 7680
100 Ω	HF45 5100	HF45 5100	82 kΩ	HF45 7820	HF45 7820
110 Ω	HJ35 5110	HF85 5110	91 kΩ	HF45 7910	HF45 7910
120 Ω	HF45 5120	HF45 5120	100 kΩ	HF45 8100	HF45 8100
150 Ω	HF45 5150	HF45 5150	110 kΩ	HF45 8110	HF45 8110
160 Ω	HJ35 5160	*	120 kΩ	HF45 8120	HF45 8120
180 Ω	HF45 5180	HF45 5180	150 kΩ	HF45 8150	HF45 8150
200 Ω	HF45 5200	HF45 5200	180 kΩ	HF45 8180	HF45 8180
220 Ω	HF45 5220	HF45 5220	220 kΩ	HJ35 8220	HF85 8220
270 Ω	HF45 5270	HF45 5270	270 kΩ	HF45 8270	HF45 8270
330 Ω	HF45 5330	HF45 5330	300 kΩ	HF45 8300	HF45 8300
390 Ω	HF45 5390	HF45 5390	330 kΩ	HF45 8330	HF45 8330
430 Ω	HF45 5430	HF45 5430	390 kΩ	HJ35 8390	HF85 8390
470 Ω	HF45 5470	HF45 5470	470 kΩ	HF45 8470	HF45 8470
510 Ω	HF45 5510	HF45 5510	560 kΩ	HJ35 8560	HF85 8560
560 Ω	HF45 5560	HF45 5560	680 kΩ	HJ35 8680	HF85 8680
680 Ω	HF45 5680	HF45 5680	820 kΩ	HJ35 8820	HF85 8820
820 Ω	HF45 5820	HF45 5820	1.0 MΩ	HF45 9100	HF45 9100
910 Ω	HF45 5910	HF45 5910	1.2 MΩ	HJ35 9120	*
1.0 kΩ	HF45 6100	HF45 6100	1.5 MΩ	HJ35 9150	HF85 9150
1.2 kΩ	HF45 6120	HF45 6120	1.8 MΩ	HJ35 9180	HF85 9180
1.5 kΩ	HF45 6150	HF45 6150	2.2 MΩ	HJ35 9220	HF85 9220
1.8 kΩ	HF45 6180	HF45 6180	3.3 MΩ	HJ35 9330	HF85 9330
2.0 kΩ	HJ35 6200	HF85 6200	3.9 MΩ	HJ35 9390	*
2.2 kΩ	HF45 6220	HF45 6220	4.7 MΩ	HJ35 9470	HF85 9470
2.4 kΩ	HJ35 6240	HF85 6240			
2.7 kΩ	HF45 6270	HF45 6270			
3.0 kΩ	HF45 6300	HF45 6300			
3.3 kΩ	HF45 6330	HF45 6330			
3.6 kΩ	HJ35 6360	HF85 6360			
3.9 kΩ	HF45 6390	HF45 6390			
4.7 kΩ	HF45 6470	HF45 6470			
5.1 kΩ	HF45 6510	HF45 6510			
5.6 kΩ	HF45 6560	HF45 6560			
6.8 kΩ	HF45 6680	HF45 6680			
8.2 kΩ	HF45 6820	HF45 6820			
9.1 kΩ	HF45 6910	HF45 6910			

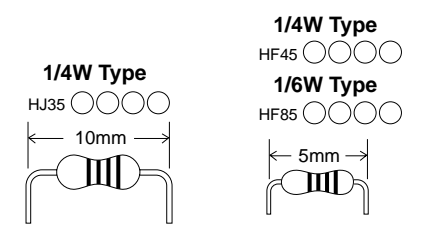

* New Parts

EXPLODED VIEW

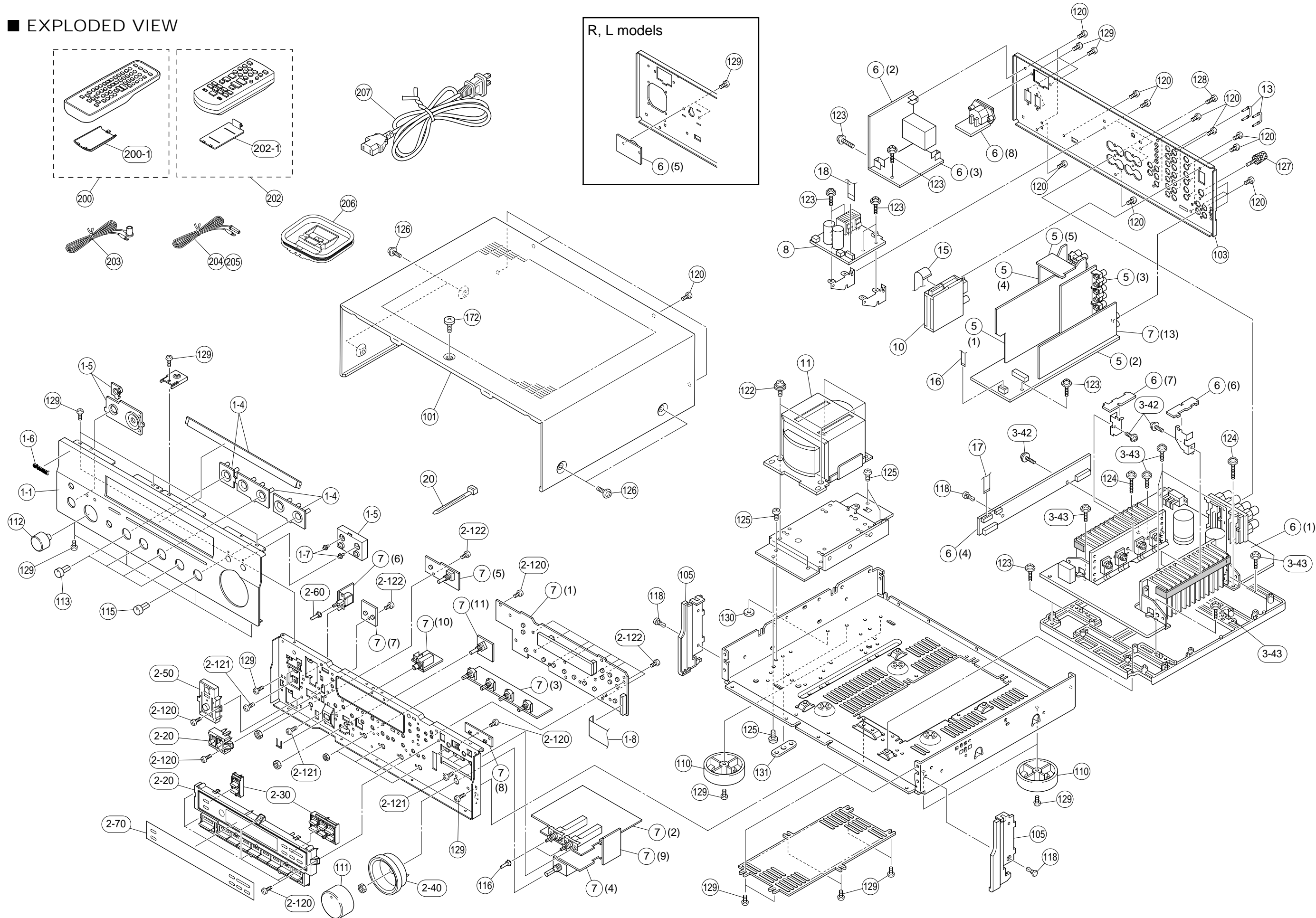
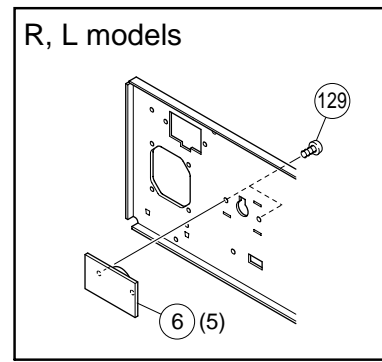

MECHANICAL PARTS

Ref. No.	Part No.	Description	Remarks	Markets
* 1-1	WF784300	FRONT PANEL	BL	UC
* 1-1	WF479000	FRONT PANEL	BL	RAGLE
* 1-1	WF479200	FRONT PANEL	TI	
* 1-4	WF486800	ESCUTCHEON R	BL	
* 1-4	WF487000	ESCUTCHEON R	TI	
1-5	WF628900	ESCUTCHEON	BL	
1-5	WF629100	ESCUTCHEON	TI	
1-6	V6034100	EMBLEM	BL, TI	
1-7	V4598900	LENS, 1P		
* 1-8	MF121250	FLEXIBLE FLAT CABLE	21P 250mm P=1.25	
* 2-20	WF484100	BUTTON CASE	BL	
* 2-20	WF484300	BUTTON CASE	TI	
* 2-30	WF485000	BUTTON TUNER		
2-40	WF486500	ESCUTCHEON VOL	BL	
2-40	WF486700	ESCUTCHEON VOL	TI	
* 2-50	WF588000	BUTTON MAIN	BL	
* 2-50	WF588300	BUTTON MAIN	TI	
2-60	V6876100	BUTTON/D5	BL	
2-60	V8540300	BUTTON/D5	TI	
* 2-70	WF488100	SHEET WINDOW R		UC
* 2-70	WF488000	SHEET WINDOW R		RAGLE
2-120	WE774300	BIND HEAD B-TIGHT SCREW	3x8 MFZN2W3	
2-121	WE774000	BIND HEAD SCREW	3x6 MFZN2W3	
2-122	WE774800	BIND HEAD P-TIGHT SCREW	3x8 MFZN2W3	
3-42	VT669300	PW HEAD B-TIGHT SCREW	3x8-8 MFC2	
3-43	VB770200	PW HEAD P-TIGHT SCREW	3x10-8 MFC2	
* 5	WG053300	P.C.B. ASS'Y	FUNCTION	UC
* 5	WG053400	P.C.B. ASS'Y	FUNCTION	RL
* 5	WG053500	P.C.B. ASS'Y	FUNCTION	A
* 5	WG053600	P.C.B. ASS'Y	FUNCTION	GE
* 6	WG051700	P.C.B. ASS'Y	MAIN	UC
* 6	WG051800	P.C.B. ASS'Y	MAIN	R
* 6	WG051900	P.C.B. ASS'Y	MAIN	A
* 6	WG052000	P.C.B. ASS'Y	MAIN	GE
* 6	WG052100	P.C.B. ASS'Y	MAIN	L
* 7	WG054500	P.C.B. ASS'Y	OPERATION	
* 8	WG055200	P.C.B. ASS'Y	XM	UC
10	V6782300	AM/FM TUNER	TFCE1U115A	UCRL
* 10	V6782400	AM/FM TUNER	TFCE1E317A	AGE
△* 11	X7153A00	POWER TRANSFORMER		UC
△* 11	X7154A00	POWER TRANSFORMER		RL
△* 11	X7155A00	POWER TRANSFORMER		A
△* 11	X7156A00	POWER TRANSFORMER		GE
13	VQ194100	SHORT PLUG	CNT31-0083 1pc	
15	MF115140	FLEXIBLE FLAT CABLE	15P 140mm P=1.25	
16	MF108100	FLEXIBLE FLAT CABLE	8P 100mm P=1.25	
17	MF114350	FLEXIBLE FLAT CABLE	14P 350mm P=1.25	
18	MF111250	FLEXIBLE FLAT CABLE	11P 250mm P=1.25	UC
20	VU590000	BINDING TIE	CBTD001B	RL
101	WF480800	TOP COVER		BL
101	WF481000	TOP COVER		TI
* 103	WF481400	REAR PANEL		UC
* 103	WF481500	REAR PANEL		R

* New Parts

Ref. No.	Part No.	Description	Remarks	Markets
* 103	WF481800	REAR PANEL		A
* 103	WF481900	REAR PANEL		L
* 103	WF482100	REAR PANEL		GE
105	WF487600	PLATE SIDE		BL
105	WF487800	PLATE SIDE		TI
110	VS025000	LEG	D60xH21	BL, TI
* 111	WF859500	KNOB D48		BL
* 111	WF859700	KNOB D48		TI
112	WC560500	KNOB D23		BL
112	WC560700	KNOB D23		TI
* 113	WF485600	KNOB		BL
* 113	WF485800	KNOB		TI
* 115	WF485900	KNOB D14L		BL
* 115	WF486100	KNOB D14L		TI
116	V6876100	BUTTON/D5		BL
116	V8540300	BUTTON/D5		TI
118	VQ368600	PUSH RIVET	P3555-B	
120	WE774100	BIND HEAD BONDING B-T. SCREW	3x8 MFZN2B3	
122	WE774700	BIND HEAD S-TIGHT SCREW	4x10 MFZN2W3	
123	VT669300	PW HEAD B-TIGHT SCREW	3x8-8 MFC2	
124	VT669400	PW HEAD B-TIGHT SCREW	3x15-8 MFC2	
125	WF821300	BIND HEAD S-TIGHT SCREW	4x7 MFZN2W3	
126	VD069600	PW HEAD S-TIGHT SCREW	4x8-10 MFN133	TI
126	VH313200	PW HEAD S-TIGHT SCREW	4x8-10 MFN13BL	BL
127	AA627310	GROUND TERMINAL		
128	VY731200	BONDING HEAD TAPPING SCREW	3x10 MFN133	
129	WE774300	BIND HEAD B-TIGHT SCREW	3x8 MFZN2W3	
130	VU984400	RING	D14	
131	V5247600	DAMPER		
172	WE200400	DISH HEAD B-TIGHT SCREW	3x6 MFN133	TI
172	WE200500	DISH HEAD B-TIGHT SCREW	3x6 MFN13BL	BL
		ACCESSORIES		
* 200	WF688700	REMOTE CONTROL	RAX100	UC
* 200	WF688800	REMOTE CONTROL	RAX101	RAGEL
200-1	AAX46580	BATTERY COVER		103RRC-244-01G
* 202	WF676400	REMOTE CONTROL	RAX17	for ZONE2 UC
* 202	WF676500	REMOTE CONTROL	RAX18	for ZONE2 RAGEL
202-1	AAX70730	BATTERY COVER		CG8912
203	V6267000	INDOOR FM ANTENNA	1.4m 1pc	UCRL
204	VQ147100	INDOOR FM ANTENNA	1.4m 1pc	A
205	VY972200	INDOOR FM ANTENNA	1.4m 1pc	GE
206	VQ307400	AM LOOP ANTENNA	81-653-645-110	
△ 207	V7704800	POWER CABLE	2m 1pc	UC
△* 207	WD107700	POWER CABLE	2m 1pc	R
△ 207	WB750900	POWER CABLE	2m 1pc	A
△ 207	V7704900	POWER CABLE	2m 1pc	GEL
△ 207	WB751000	POWER CABLE	2m 1pc	L
		BATTERY, MANGANESE DRY	UM-3	
		BATTERY, MANGANESE DRY	UM-4	

* New Parts

REMOTE CONTROL RAX100/RAX101

SCHEMATIC DIAGRAM

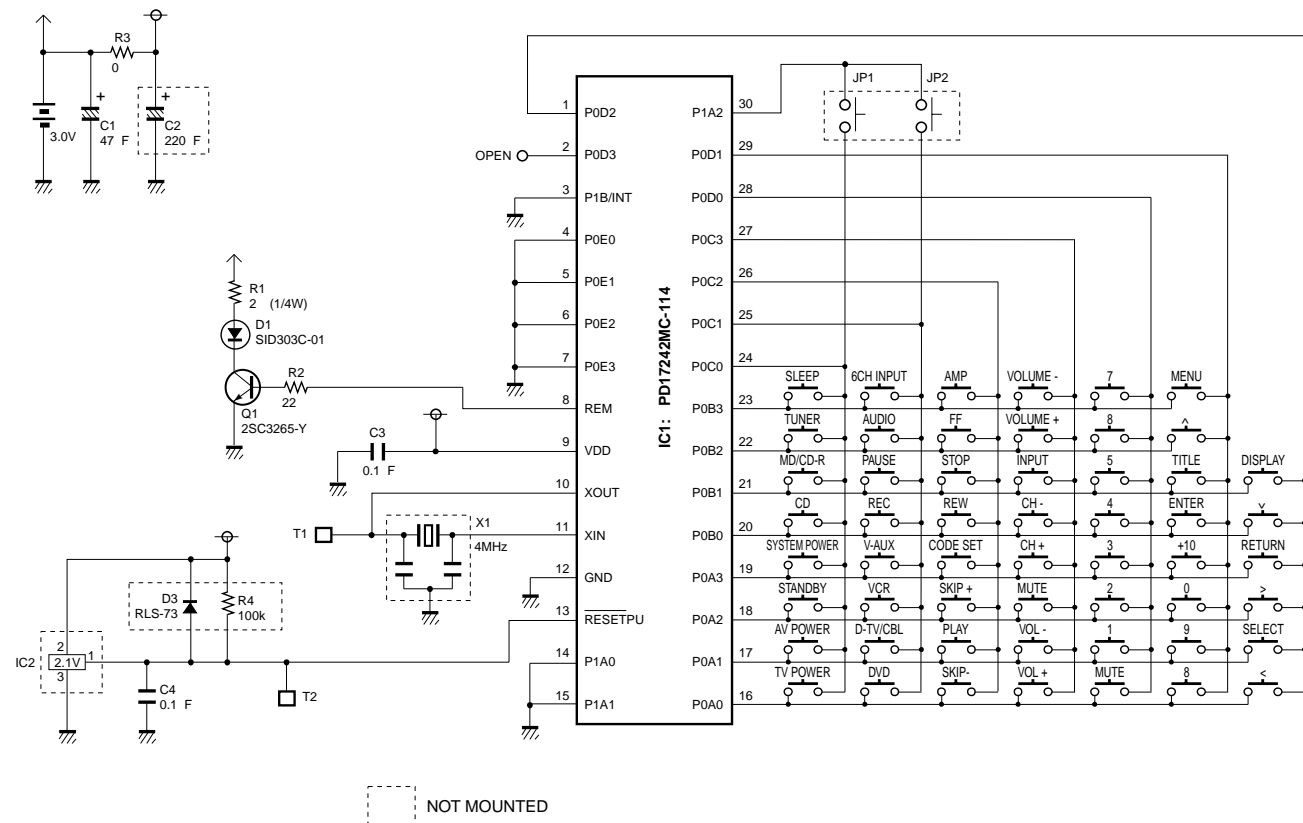

NOT MOUNTED

▼ RAX100 (U, C models)

▼ RAX101 (R, A, G, E, L models)

KEY NO. LAYOUT

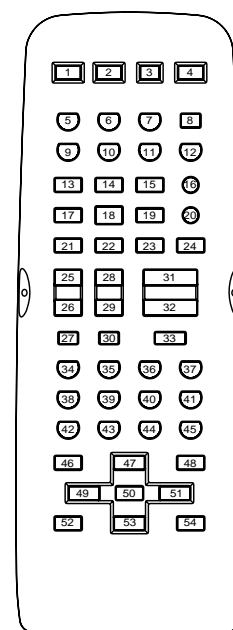
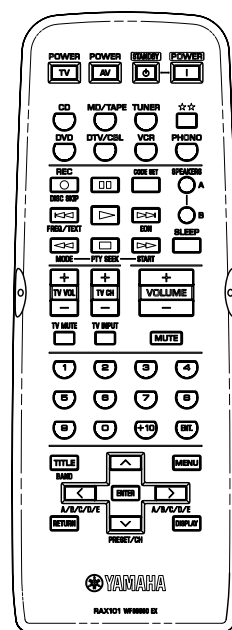
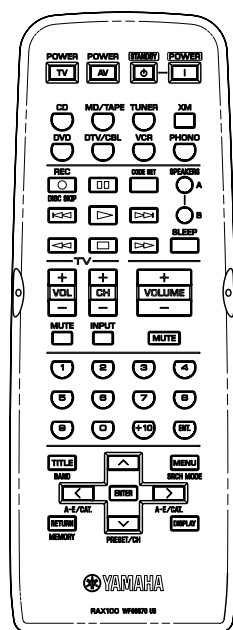

DATA CODE LIST

Key No.	Function	CODE							
		COMMON	CD	TAPE	MD	CD-R	DVD	TUNER	XM
1	TV POWER	-	-	-	-	-	-	-	-
2	AV POWER	-	-	-	-	7F-80	7C-80	-	-
3	STANDBY	7E-7F	-	-	-	-	-	-	-
4	SYSTEM POWER	7E-7E	-	-	-	-	-	-	-
5	CD	7A-15	-	-	-	-	-	-	-
6	MD/TAPE	7A-18	-	-	-	-	-	-	-
7	TUNER	7A-16	-	-	-	-	-	-	-
8	XM ☆☆	7A-B4	-	-	-	-	-	-	-
9	DVD	7A-C1	-	-	-	-	-	-	-
10	DTV/CBL	7A-54	-	-	-	-	-	-	-
11	VCR	7A-0F	-	-	-	-	-	-	-
12	PHONO	7A-14	-	-	-	-	-	-	-
13	REC/DISK SKIP	-	7A-4F	7A-04	79-AF	-	7C-8B	-	-
14	PAUSE	-	7A-09	7A-06	79-A9	7F-83	7C-83	-	-
15	CODE SET	-	-	-	-	-	-	-	-
16	SPEAKERS A	7A-9A	-	-	-	-	-	-	-
17	SKIP -	-	7A-0B	7A-07	A9-AB	7F-86	7C-B9	7A-A4	-
18	PLAY	-	7A-08	7A-00	79-A8	7F-82	7C-82	-	-
19	SKIP +	-	7A-0A	7A-40	79-AE	7F-87	7C-BA	7A-A5	-
20	SPEAKERS B	7A-9B	-	-	-	-	-	-	-
21	REW	-	7A-0D	7A-01	79-AC	7F-88	7C-86	7A-A6	-
22	STOP	-	7A-09	7A-03	79-AA	7F-84	7C-85	-	-
23	FF	-	7A-0C	7A-02	79-AD	7F-89	7C-87	7A-A7	-
24	SLEEP	7A-57	-	-	-	-	-	-	-
25	TV VOL +	-	-	-	-	-	-	-	-
26	TV VOL -	-	-	-	-	-	-	-	-
27	TV MUTE	-	-	-	-	-	-	-	-
28	TV VH +	-	-	-	-	-	-	-	-
29	TV CH -	-	-	-	-	-	-	-	-
30	TV INPUT	-	-	-	-	-	-	-	-
31	VOL up	7A-1A	-	-	-	-	-	-	-
32	VOL down	7A-1B	-	-	-	-	-	-	-
33	MUTE	7A-1C	-	-	-	-	-	-	-
34	1	-	79-11	-	79-85	7F-91	7C-94	7A-E5	7A-61
35	2	-	79-12	-	79-86	7F-92	7C-95	7A-E6	7A-62
36	3	-	79-13	-	79-87	7F-93	7C-96	7A-E7	7A-63
37	4	-	79-14	-	79-88	7F-94	7C-97	7A-E8	7A-64
38	5	-	79-15	-	79-89	7F-95	7C-98	7A-E9	7A-65
39	6	-	79-16	-	79-8A	7F-96	7C-99	7A-EA	7A-66
40	7	-	79-17	-	79-8B	7F-97	7C-9A	7A-EB	7A-67
41	8	-	79-18	-	79-8C	7F-98	7C-9B	7A-EC	7A-68
42	9	-	79-19	-	79-8D	7F-99	7C-9C	7A-B1	7A-69
43	0	-	79-10	-	79-8E	7F-90	7C-93	7A-B2	7A-60
44	+10	-	9-1A	-	79-8F	7F-9A	7C-9D	-	-
45	ENT	-	79-0B	-	-	7F-8A	7C-9E	7A-B3	7A-8F
46	TITLE	-	-	-	-	-	7C-B1	7A-AE	7A-70
47	UP	-	-	-	-	-	7C-B4	7A-10	7A-6A
48	MENU	-	-	-	-	-	7C-B2	7A-AB	7A-6D
49	LEFT	-	-	-	-	-	7C-B5	7A-AC	7A-6E
50	SELECT	-	-	-	-	-	7C-B8	7A-AD	7A-6F
51	RIGHT	-	-	-	-	-	7C-B6	7A-12	7A-6C
52	RETURN	-	-	-	-	-	7C-B7	7A-AF	7A-71
53	DOWN	-	-	-	-	-	7C-B3	7A-11	7A-6B
54	DISPLAY	-	79-0A	-	79-A5	7F-9E	7C-A6	7A-B0	7A-72

REMOTE CONTROL RAX17

SCHEMATIC DIAGRAM

KEY NO. LAYOUT

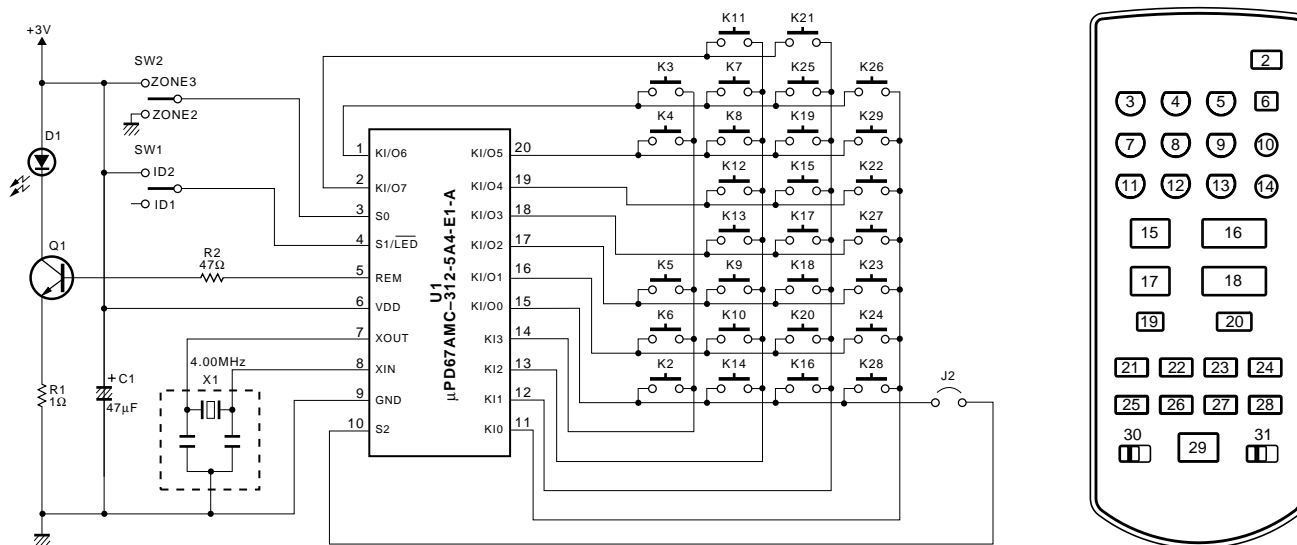

YAMAHA RAX17 IR CODE TABLE

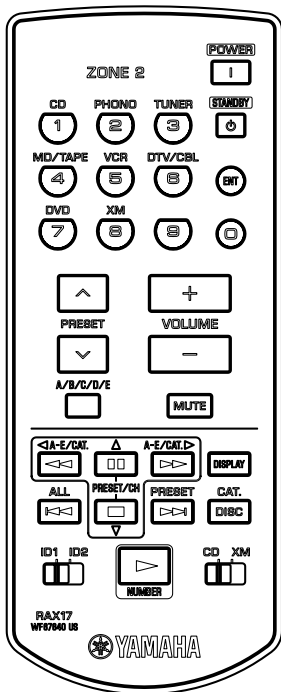

Key No.	Key Name	code									
		ID1 (ZONE2)		XM		ID2 (ZONE2) (default)					
		ID1+CD	ID1+XM	With pressing Key No. 29		ID2+CD	ID2+XM	With pressing Key No. 29			
1	(no key)	(no code)	(no code)	(no code)	(no code)	(no code)	(no code)	(no code)	(no code)	(no code)	
2	POWER	7E-BA	(no code)	(no code)	(no code)	7D-64	(no code)	(no code)	(no code)	(no code)	
3	CD	7A-D1	(no code)	1	7A-61	7D-67	(no code)	1	7D-A1	(no code)	
4	PHONO	7A-D0	(no code)	2	7A-62	7D-65	(no code)	2	7D-A2	(no code)	
5	TUNER	7A-D2	(no code)	3	7A-63	7D-66	(no code)	3	7D-A3	(no code)	
6	STANDBY	7E-BB	(no code)	(no code)	(no code)	7D-63	(no code)	(no code)	(no code)	(no code)	
7	MD/TAPE	7A-D3	(no code)	4	7A-64	7D-6A	(no code)	4	7D-A4	(no code)	
8	VCR	7A-D6	(no code)	5	7A-65	7D-6D	(no code)	5	7D-A5	(no code)	
9	DTV/CBL	7A-D9	(no code)	6	7A-66	7D-6C	(no code)	6	7D-A6	(no code)	
10	ENT	(no code)	(no code)	ENT	7A-BF	(no code)	(no code)	ENT	7D-3F	(no code)	
11	DVD	7A-CD	(no code)	7	7A-67	7D-6F	(no code)	7	7D-A7	(no code)	
12	XM	7A-D8	(no code)	8	7A-68	7D-2F	(no code)	8	7D-A8	(no code)	
13	9	(no code)	(no code)	9	7A-69	(no code)	(no code)	9	7D-A9	(no code)	
14	0	(no code)	(no code)	0	7A-60	(no code)	(no code)	0	7D-A0	(no code)	
15	PRESET (+)	7A-10	(no code)	(no code)	(no code)	7D-F5	(no code)	(no code)	(no code)	(no code)	
16	VOLUME (+)	7A-DA	(no code)	(no code)	(no code)	7D-70	(no code)	(no code)	(no code)	(no code)	
17	PRESET (-)	7A-11	(no code)	(no code)	(no code)	7D-F6	(no code)	(no code)	(no code)	(no code)	
18	VOLUME (-)	7A-DB	(no code)	(no code)	(no code)	7D-71	(no code)	(no code)	(no code)	(no code)	
19	A/B/C/D/E	7A-12	(no code)	(no code)	(no code)	7D-F7	(no code)	(no code)	(no code)	(no code)	
20	MUTE	7A-DC	(no code)	(no code)	(no code)	7D-72	(no code)	(no code)	(no code)	(no code)	
21	Device	REW	7A-0D	A-E/CAT (-)	7A-6D	(no code)	REW	7A-0D	A-E/CAT (-)	7D-35	(no code)
22	Device	PAUSE	7A-09	PRESET/CH (+)	7A-6A	(no code)	PAUSE	7A-09	PRESET/CH (+)	7D-31	(no code)
23	Device	FF	7A-0C	A-E/CAT (+)	7A-6C	(no code)	FF	7A-0C	A-E/CAT (+)	7D-33	(no code)
24	Device	DISPLAY	79-0A	DISPLAY	7A-72	(no code)	DISPLAY	79-0A	DISPLAY	7D-39	(no code)
25	Device	SKIP (-)	7A-0B	ALL	7A-B5	(no code)	SKIP (-)	7A-0B	ALL	7D-2C	(no code)
26	Device	STOP	7A-09	PRESET/CH (-)	7A-6B	(no code)	STOP	7A-09	PRESET/CH (-)	7D-32	(no code)
27	Device	SKIP (+)	7A-0A	PRESET	7A-B7	(no code)	SKIP (+)	7A-0A	PRESET	7D-2E	(no code)
28	Device	DISK SKIP	7A-4F	CAT	7A-B6	(no code)	DISK SKIP	7A-4F	CAT	7D-2D	(no code)
29	Device	PLAY	7A-08	NUMBER	(no code)	(no code)	PLAY	7A-08	NUMBER	(no code)	(no code)
30	ID1/ID2										
31	CD/XM										

REMOTE CONTROL RAX18

SCHEMATIC DIAGRAM

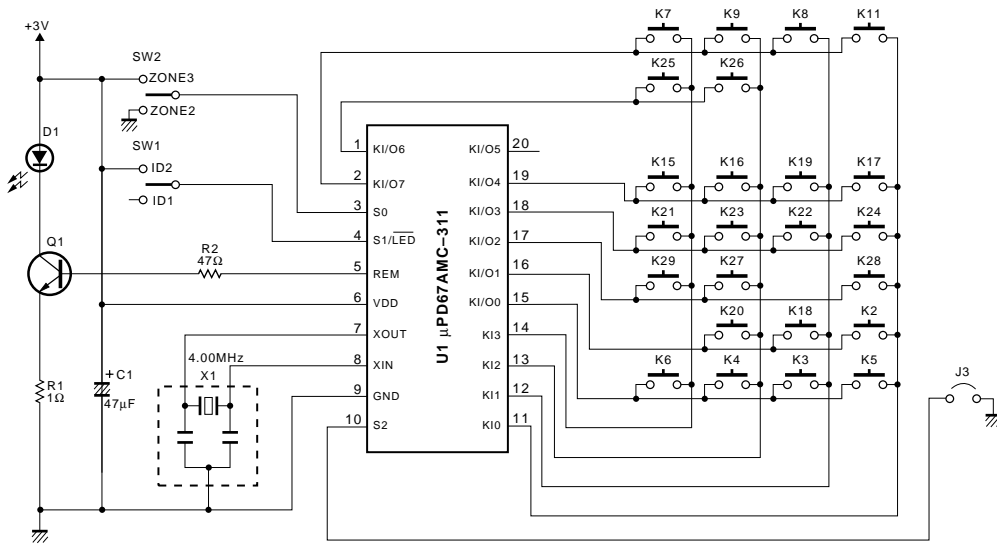

KEY NO. LAYOUT

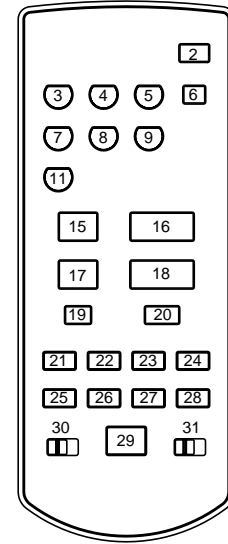

YAMAHA RAX18 IR CODE TABLE

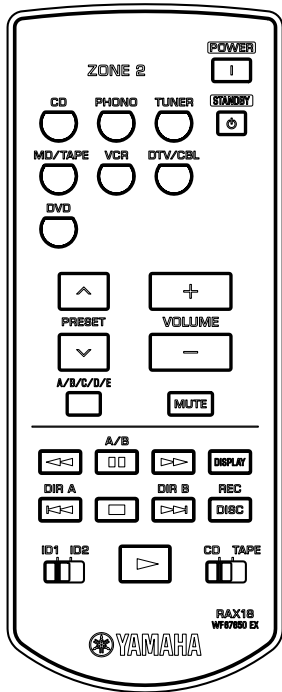

Key No.	Key Name	code							
		ID1 (ZONE2)				ID1 (ZONE2) (default)			
		CD		TAPE		CD		TAPE	
1	(no key)	(no code)				(no code)			
2	POWER	7E-BA				7D-64			
3	CD	7A-D1				7D-67			
4	PHONO	7A-D0				7D-65			
5	TUNER	7A-D2				7D-66			
6	STANDBY	7E-BB				7D-63			
7	MD/TAPE	7A-D3				7D-6A			
8	VCR	7A-D6				7D-6D			
9	DTV/CBL	7A-D9				7D-6C			
10	(no key)	(no code)				(no code)			
11	DVD	7A-CD				7D-6F			
12	(no key)	(no code)				(no code)			
13	(no key)	(no code)				(no code)			
14	(no key)	(no code)				(no code)			
15	PRESET (+)	7A-10				7D-F5			
16	VOLUME (+)	7A-DA				7D-70			
17	PRESET (-)	7A-11				7D-F6			
18	VOLUME (-)	7A-DB				7D-71			
19	A/B/C/D/E	7A-12				7D-F7			
20	MUTE	7A-DC				7D-72			
21	Device	REW	7A-0D	REW	7A-01	REW	7A-0D	REW	7A-01
22	Device	PAUSE	7A-09	A/B	7A-06	PAUSE	7A-09	A/B	7A-06
23	Device	FF	7A-0C	FF	7A-02	FF	7A-0C	FF	7A-02
24	Device	DISPLAY	79-0A	(no code)		DISPLAY	79-0A	(no code)	
25	Device	SKIP (-)	7A-0B	DIR A	7A-07	SKIP (-)	7A-0B	DIR A	7A-07
26	Device	STOP	7A-09	STOP	7A-03	STOP	7A-09	STOP	7A-03
27	Device	SKIP (+)	7A-0A	DIR B	7A-04	SKIP (+)	7A-0A	DIR B	7A-04
28	Device	DISC SKIP	7A-4F	REC	7A-04	DISC SKIP	7A-4F	REC	7A-04
29	Device	PLAY	7A-08	PLAY	7A-00	PLAY	7A-08	PLAY	7A-00
30	ID1/ID2								
31	CD/TAPE								